



ENAPART



93 S Railroad Avenue Unit C
Bergenfield NJ 07621 USA
www.enapart.com
sales@enapart.com



Via del Canneto 35,
Borgosatollo, Brescia - Italia
www.enapart.it
vendite@enapart.it



Barbaros Mah. Ihlamur Bul. Aĝaoĝlu
My Newwork No:3/15 Ataşehir / İstanbul
www.enapart.net
satis@enapart.net



PRIVADA 10 B SUR #3908 COL.
ANZUREZ, C.P. 72530, PUEBLA, PUE
www.enapart.com.mx
sales@enapart.com.mx



Friedrich-Ebert-Anlage 36, 60325
Frankfurt am Main, Germany
www.enapart.de
anfrage@enapart.de



4 boulevard Carnot, 95400
villiers-le-bel, Paris, France
www.enapart.fr
sales@enapart.fr



65049, ОДЕСА, ВУЛИЦЯ ІВАНА
ФРАНКА, БУДИНОК 55, ПОВЕРХ 3
www.enapart.com.ua
sales@enapart.com.ua



MUNICIPIUL BUCUREȘTI, SECTOR 3,
B-DUL BASARABIA, NR.250, CORP P+5
www.enapart.ro
sales@enapart.ro



〒584-0023 大阪府富田林市若松町
東2丁目2番16号
www.enapart.co.jp
sales@enapart.co.jp



PLAZA NUESTRA SEÑORA DE LAS
NIEVES 12 ,LOCAL ,50012,ZARAGOZA
www.enapart.es
ventas@enapart.es



Складова база „Онгъл“, Склад А2, п.к.
4006, гр. Пловдив, България
www.enapart.bg
sales@enapart.bg



3 Austin Mews, High Street, Hemel
Hempstead, HP1 3AF , United Kingdom
www.enapart.co.uk
sales@enapart.co.uk

FEATURES :

The features showed on catalogue represent the average value obtained from a series of tests carried out on some valves. It's not possible to assure that all products will have the same performances and a tolerance of +/- 10%, if not different indicated, is allowed.

NOMINAL FLOW AND MAX. FLOW :

The nominal flow showed in all valve's technical sheet, is to be considered as a flow value which can be used continuously. This value may intermittent coincide with max. pressure.

The max. applicable flow, is showed in any chart, as range bottom flow value or as break of performance line.

The max. flow, if exceptionally used, does not compromise the valve working.

Max. pressure never coincides with max. flow.

We remind that sometimes, the max. flow is not the plant feeding pump flow.

On regenerative circuits where accumulators or cylinder high differential are present, the real flows crossing the valves are much more higher.

MAX. PRESSURE :

Has to be considered as an absolute limit that may never be exceeded, even for very short periods.

We suggest to operate with a value under 25% in order to obtain a long lasting live of components.

USE LIMITS :

Some catalogues show, on diagram side, combination values between flow and pressure.

These values are to be considered as max. values which may never be exceeded.

LEAKAGE :

All poppet-type valves test is executed with high precision instruments aid and stiff connections.

This allows to state that all valves passing this test have null leakage. It doesn't prevent working condition from being determining for leakage. Impurity particles present in hydraulic oil, heavy duty service, etc... may change the correct valve working and may influence the seal.

WORKING PRINCIPLE :

In contests at the beginning of each section, each valve is represented in schematic section. Near the valve the allowed directions of flows are showed by arrows. We recommend to respect always these indications.

IDENTIFICATION :

All cartridge valves are stamped with Mark, Valve Code and Date of production.

All standard valve bodies are stamped with ports standard numbering and are stamped directly on body itself or on a special label with Mark, Body Code and Date of production. Special Blocks are stamped with Ports Code and, directly on body or on a special label, with Mark, Group Code and Date of production.

SPECIAL AND STANDARD TEST :

All cartridge valve are tested at 100% with a nominal flow and max. pressure. If they are control equipped, they are set, if not otherwise required, at a standard pressure value showed in the choice code of each valve.

By solenoid valves, all coils are tested and the strength and insulation valves are pointed out.

Special integrated blocks are dimensionally tested and, on request, block different functions may be tested.

More over it is possible to customize test, to fix methods and test parameter in accordance with our Customers and on request we grant certifications.

ORDERING CODE :

The choice variants showed in each catalogues allow to combine an ordering code easy to use.

At each available ordering code side, appear the corresponding Code of Complete Group.

SPARE PARTS :

At the end of Complete Group Code of any valves, the external spear Kit seals Code are quoted.

TAMPERING :

All the cartridge valves are not made to be disassembled.

Forcing this operation you can compromise the correct valve working and any way cancel the warranty.

Every tampering must be authorized by factory.

WARRANTY :

Flucom warrants its products free from defects in material, workmanship and design for a period of one year after installation date, and two years after production date.

O-Rings, seals and springs are specifically exempted from this warranty. Flucom cannot accept responsibility of any type for any of its products that have been repaired or altered outside the Flucom factory.

The warranty concern the replacement or correction, f.o.b. our factory, of any defective part or product determined by inspection as not conforming to this warranty. We are not responsible for any consequential damages resulting from use by any buyer or user, as our liability is restricted to the value of sold products and made us replace defective parts.

Written permission for any warranty returns must be obtained from Flucom prior to shipment.

Ship all warranty returns freight prepaid including a complete explanation of the defects and circumstance.

INHIBITING TREATMENT :

All cartridges are zinc plated; solenoid mechanical parts are protected by phosphatizing.

All aluminium body are anodized; on request steel body can be galvanized or phosphated.

SOLENOIDS USE :

All solenoids are made by high quality material, according to standard VDE 0580.

They are built in three size, 20-30-50 series, different voltage AC-DC, with connection DIN 43650 and KOSTAL M 27x1.

Seats for O-Ring seals fitting up in order to protect the tube are foreseer, complete with serigraphy showing the main plate data. The coils can be feed by direct current with standard connectors aid, and by alternating current using connectors provided with incorporated rectifier bridge.

Voltage range +/- 10%.

For performances and dimensions see catalogue 09.900 - 09.901 (coils) and catalogue 09.910 (connectors).

All standard coils allow continuous use (ED 100%) and a safety protection range of IP 65.

RECOMMENDED TORQUES :

The schedule represents the recommended torques.

Before to assembly we suggest to grease showed points for seals longlife.

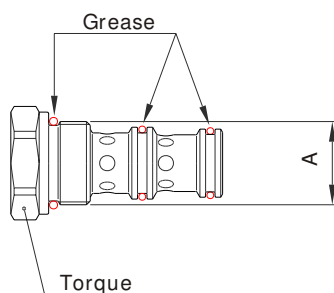

Series	A	Nm
20	M 18x1.5	35-40
30	M 22x1.5	50-60
50	M 33x2	100-120
70	M 42x2	180-210

Series	A	Nm
28	3/4-16 UNF	40-45
32	M 20x1.5	42-47
38	7/8-14 UNF	50-60

Some valves may have different clamping torque. Always verify the exactly value showed on technical schedules.

TAMPERING :

All the cartridge valves are not made to be disassembled.

Forcing this operation you can compromise the correct valve working and any way cancel the warranty.

Every tampering must be authorized by factory.

WARRANTY :

Flucom warrants its products free from defects in material, workmanship and design for a period of one year after installation date, and two years after production date.

O-Rings, seals and springs are specifically exempted from this warranty. Flucom cannot accept responsibility of any type for any of its products that have been repaired or altered outside the Flucom factory.

The warranty concern the replacement or correction, f.o.b. our factory, of any defective part or product determined by inspection as not conforming to this warranty. We are not responsible for any consequential damages resulting from use by any buyer or user, as our liability is restricted to the value of sold products and made us replace defective parts.

Written permission for any warranty returns must be obtained from Flucom prior to shipment.

Ship all warranty returns freight prepaid including a complete explanation of the defects and circumstance.

INHIBITING TREATMENT :

All cartridges are zinc plated; solenoid mechanical parts are protected by phosphatizing.

All aluminium body are anodized; on request steel body can be galvanized or phosphated.

SOLENOIDS USE :

All solenoids are made by high quality material, according to standard VDE 0580.

They are built in three size, 20-30-50 series, different voltage AC-DC, with connection DIN 43650 and KOSTAL M 27x1.

Seats for O-Ring seals fitting up in order to protect the tube are foreseer, complete with serigraphy showing the main plate data. The coils can be feed by direct current with standard connectors aid, and by alternating current using connectors provided with incorporated rectifier bridge.

Voltage range +/- 10%.

For performances and dimensions see catalogue 09.900 - 09.901 (coils) and catalogue 09.910 (connectors).

All standard coils allow continuous use (ED 100%) and a safety protection range of IP 65.

RECOMMENDED TORQUES :

The schedule represents the recommended torques.

Before to assembly we suggest to grease showed points for seals longlife.

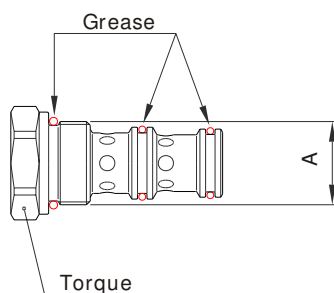

Series	A	Nm
20	M 18x1.5	35-40
30	M 22x1.5	50-60
50	M 33x2	100-120
70	M 42x2	180-210

Series	A	Nm
28	3/4-16 UNF	40-45
32	M 20x1.5	42-47
38	7/8-14 UNF	50-60

Some valves may have different clamping torque. Always verify the exactly value showed on technical schedules.

SPECIAL AND STANDARD ADJUSTMENT :

Here are showed the main adjustments available for mainly cartridge valves.

For different solutions please ask our Seals Department. All regulations showed are seal-adjustments.

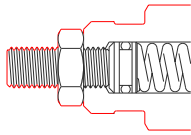

Type **N** Standard adjustment - External screw with clamping nut.

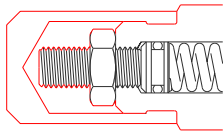

Type **NI** Standard adjustment - N type with tamper proof, irremovable after calibration.

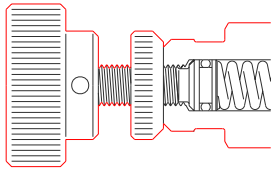

Type **V** Standard adjustment - Handknob with clamping lock ring.

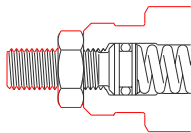

Special adjustment - External integral screw with oversight protection and clamping nut.

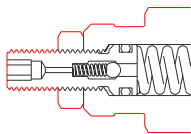

Type **L** For some valves an air vent-hole in spring-chamber is foreseen and it is obtained in regulating screw. On this version it is not possible to assemble the prevention cap type LB.

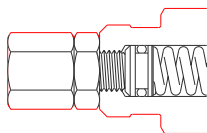

Type **NB** Special adjustment - N type with prevention cap.

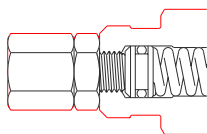

Type **LB** Special adjustment - L type with prevention cap.

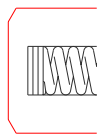

Type **F** Special adjustment - Fixed setting (by factory).

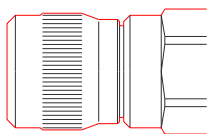

Type **H** Standard adjustment for some flow control valves - The rotation effort keeps unchanged even at high pressure.

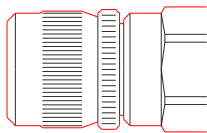

Type **HG** Standard adjustment - H type with clamping lock ring.

USE OF FORMING TOOLS :

Here are showed the four working phases in order to obtain an unified cavity. We recommend to respect concentricity marked in schedules n. 17.000 and 17.001.

In the under mentioned code-table are marked the cavities code and pre-drilled diameters.

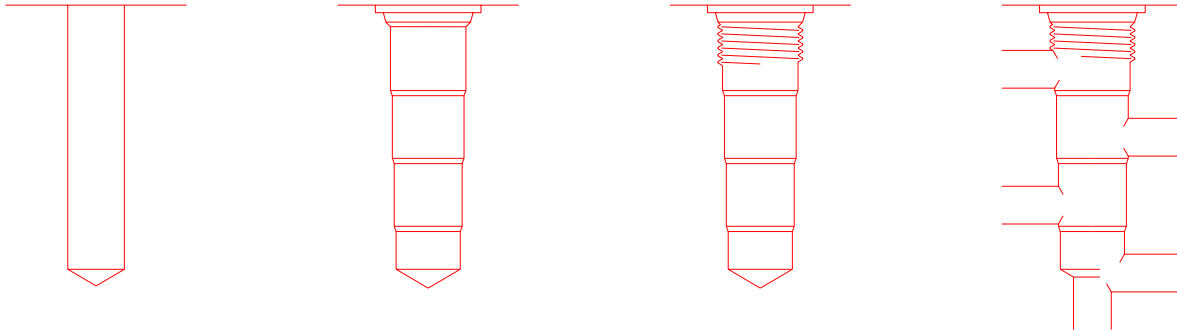

Pre-drilled hole

Forming tool

Tapping

Radial holes

Cavity type	Cavity code	Pre-drilled hole	Forming tool code	Tap type
20 2 way	S20/2	∅ max. 14	89 328 101	M 18x1.5
20 3 way	S20/3	∅ max. 13	89 328 102	
20 4 way	S20/4	∅ max. 12	89 328 103	
30 2 way	S30/2	∅ max. 18	89 328 104	M 22x1.5
30 3 way	S30/3	∅ max. 17	89 328 105	
30 4 way	S30/4	∅ max. 16	89 328 106	
50 2 way	S50/2	∅ max. 27	89 328 107	M 33x2
50 3 way	S50/3	∅ max. 26	89 328 108	
50 4 way	S50/4	∅ max. 25	89 328 109	
70 2 way	S70/2	∅ max. 37	89 328 110	M 42x2
70 3 way	S70/3	∅ max. 35	89 328 111	
70 4 way				

SEALS :

On all standard valves are used special polyurethane seals which do not require back-up rings and grant an effective seal till static pressure of 600 bar.

Seals used on thread are in accordance with ISO 6149 and are manufactured with compounding Buna N 70 or 90 Shore A. Standard seals bear a temperature range from -35 C to +110 or 90 Shore A. Standard seals bear a temperature range from -35 C.

On request seals with different compounding may be assembled; please ask our Technical Department.

FLUIDS AND FILTRATION :

Standard seals are suitable for being used with usual hydraulic oils with mineral base type HM and HV according to ISO 6074. On technical schedules of each valve are showed the beared viscosity range as well as the required filtration level.

We recommend to respect these limits in order to obtain an high reliability and a long lasting life of components.

Sizes:

This page represents the four Standard Size, the Special Versions and the Ports number.

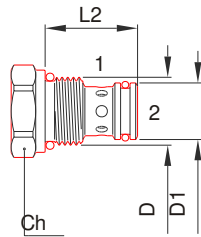
2 way

Size	Dimensions (mm)			
	D	D1	Ch	L2
(N) 20	M 18x1.5	15	22	24.5
(S) 28	3/4-16 UNF	12.7	24	27
(S) 29	3/4-16 UNF	15.8	24	26.5
(N) 30	M 22x1.5	19	27	28
(S) 32	M 20x1.5	15	24	25
(N) 50	M 33x2	28	38	39
(N) 70	M 42x2	38	50	48

(N) Standard Flucom sizes (ISO 6149)

(S) Other sizes

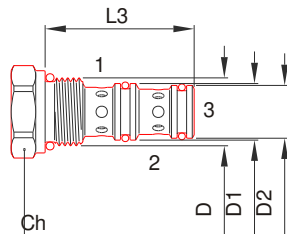
3 way

Size	Dimensions (mm)				
	D	D1	D2	Ch	L3
(N) 20	M 18x1.5	15	14	22	39.5
(S) 28	3/4-16 UNF	15.8	14.2	24	40.5
(N) 30	M 22x1.5	19	18	27	46
(N) 50	M 33x2	28	27	38	63
(N) 70	M 42x2	38	36	50	79

(N) Standard Flucom sizes (ISO 6149)

(S) Other sizes

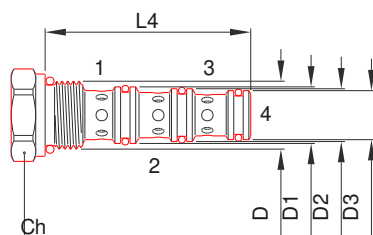
4 way

Size	Dimensions (mm)					
	D	D1	D2	D3	Ch	L4
(N) 20	M 18x1.5	15	14	13	22	54.5
(S) 28	3/4-16 UNF	15.8	14.2	12.7	24	55
(N) 30	M 22x1.5	19	18	17	27	64
(N) 50	M 33x2	28	27	26	38	88
(N) 70	M 42x2	38	36	-	50	-

(N) Standard Flucom sizes (ISO 6149)

(S) Other sizes

Pressure relief valves.

They are indispensable in most of all hydraulic applications in order to limit the pressure, to prevent shocks and to protect from overload. They are classified in direct acting and pilot operated valves and are manufactured in many models. The following schedule reports the main technical and use features: for further informations please look up in the technical detailed schedules.

Main features	Type	Q max. (l/min.)	P max. (bar)	Technical schedule
LPS 20 series - direct acting ball-type. They have good reseal without pressure peack. Are used for remote control of valves or logical elements and for infrequent duty relief or thermal expansion relief.	LPS 20	2	420	02.020
	LPS 20/ 20	12	420	02.030
LPE series - direct acting guided conical poppet-type. They have't a pressure peack, the pressure-flow trend is good. Generally are used as main pressure relief valve for continuous service or in dual cross-over valves in frequent intermittences applications.	LPE 20	30	210	02.040
	LPA series - direct acting guided conical poppet-type. They have a low pressure peack and a good flow-pressure trend. Generally are used as main pressure relief valve for continuous service.	LPA 20	20	350
LPB series - direct acting differential poppet-type. They can stand high back pressure and have fast act with low pressure peack. Mainly are used as dual cross-over valves in frequent intermittences applications.	LPA 30	50	350	02.070
	LPB 20	50	350	02.080
	LPB 30	90	350	02.090
	LPB 50	160	350	02.100
LPI series - pilot operating spool-type. They distinguish themselves by their first-rate stability, their large passing orifice and their good reseal. Thanks to the very good flow-pressure trend, they are recommended for industrial applications which may result particularly heavy and for continuous service.	LPB 70	360	350	02.110
	LPI 30	90	420	02.120
	LPI 50	160	420	02.130
LPT series - direct acting spool-type for low pressure settings.	LPI 70	320	420	02.140
	LPT 30	30	50	02.160

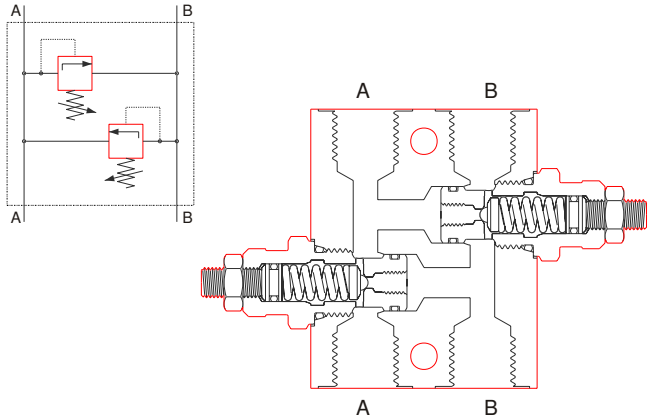
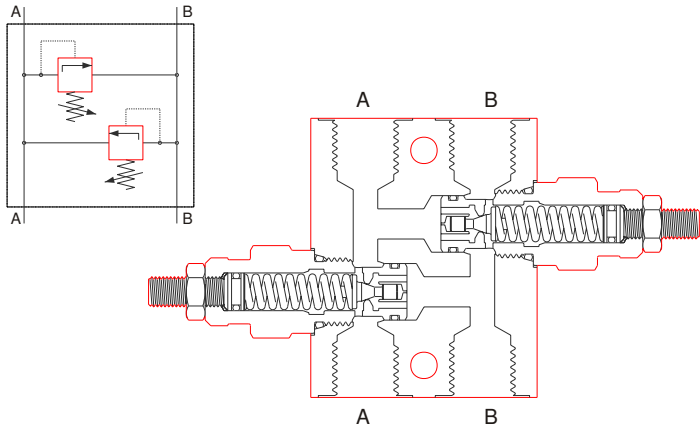
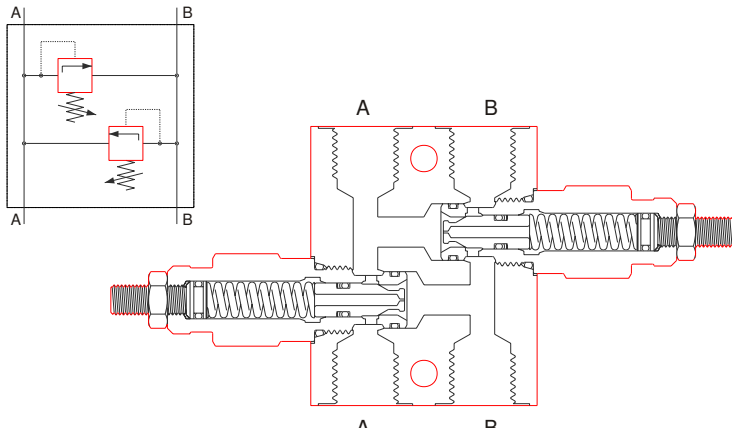
Main features	Type	Q max. (l/min.)	P max. (bar)	Technical schedule
<p>LPS 20/ 20 series CSL 03 circuit.</p> <p>They assemble two relief valves, series LPS 20/20 and are utilized to prevent shocks or are used as protection from thermal expansions. They can only be used on hydraulic motors or on actuators having the same displacement on both parts.</p> 	LPS 20/ 20 CSL 03	12	315	02.210
<p>LPE and LPA series CSL 03 circuit.</p> <p>They assemble two relief valves, series LPE or LPA and are used to control pressure on both line A and line B. They can only be used on hydraulic motor or on actuator having the same displacement on both parts.</p> 	LPE 20 CSL 03	30	210	02.215
	LPA 20 CSL 03	20	210	02.220
	LPA 30 CSL 03	50	210	02.230
<p>LPB series CSL 03 circuit.</p> <p>They assemble two relief valves, series LPB, are used as dual cross over valve on both lines. They can only be used on hydraulic motors or on actuators having the same displacement on both parts.</p> 	LPB 20 CSL 03	50	350	02.240
	LPB 30 CSL 03	90	350	02.250
	LPB 50 CSL 03	160	350	02.260
	LPB 70 CSL 03	360	350	02.270

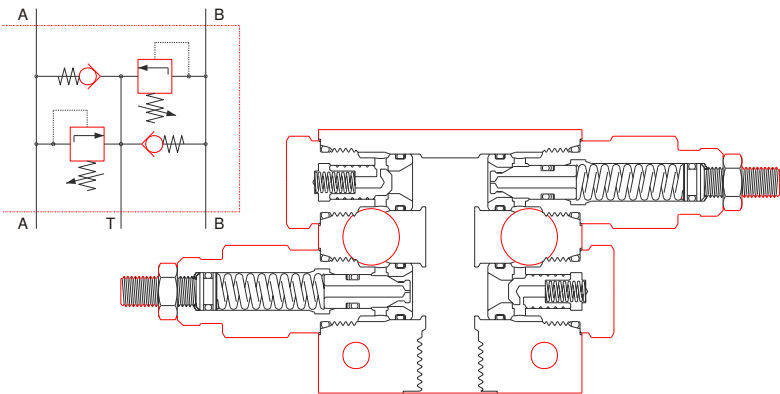
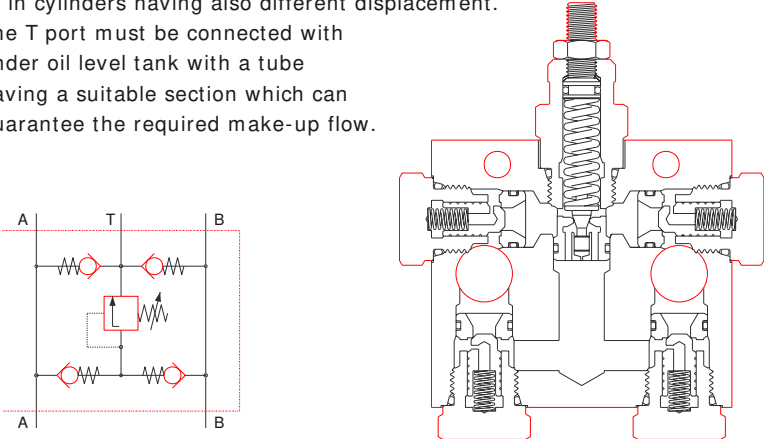
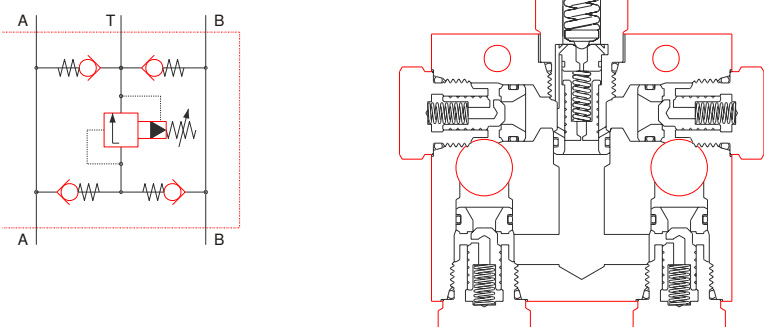
Main features	Type	Q max. (l/min.)	P max. (bar)	Technical schedule
<p>LPB series CSL 04 circuit.</p> <p>They assemble two pressure relief valves series LPB and two check valves. Generally are used as dual relief make-up check valves in hydraulic motors or in cylinders having also different displacement.</p> <p>The T port must be connected with under oil level tank with a tube having a suitable section which can guarantee the required make-up flow.</p> 	LPB 20 CSL 04	50	350	02.300
	LPB 30 CSL 04	90	350	02.310
	LPB 50 CSL 04	160	350	02.320
	LPB 70 CSL 04	360	350	02.330
<p>LPE and LPA series CSL 06 circuit.</p> <p>They assemble one pressure relief valve series LPE or LPA and four check valves. Generally are used as dual relief make-up check valves in hydraulic motors or in cylinders having also different displacement.</p> <p>The T port must be connected with under oil level tank with a tube having a suitable section which can guarantee the required make-up flow.</p> 	LPE 20 CSL 06	30	210	02.335
	LPA 20 CSL 06	20	350	02.340
	LPA 30 CSL 06	50	350	02.350
<p>LPI series CSL 06 circuit.</p> <p>They have functional features like LPE and LPA-CSL 06 series, the pilot valves series LPI use, allows to operate with higher flows and pressures.</p> 	LPI 30 CSL 06	90	420	02.360
	LPI 50 CSL 06	160	420	02.370
	LPI 70 CSL 06	320	420	02.380

Pressure reducing valves.

They are indispensable when it's necessary to operate with different pressure in one-pump circuit.
Are divided into two execution-types: direct acting and pilot operated.

DI RECT ACTING: They are produced only in series 20 and are suitable for narrow flows and reduced maximal pressure of 105 bar. They distinguish themselves by their very low leakage and good tolerance at oil contaminations.

PILOT OPERATED Are used when higher flows or high pressure are required; more sensitive at oil contaminations have constant drain flow of 0.4-0.6 l/min.

Main features	Type	Q max. (l/min.)	P / Pr (bar)	Technical schedule
<p>RPA series - direct acting spool-type. Fast acting, good stability, impurity endurance, particularly suitable for narrow flows and reduced low pressure (max. 80 bar).</p>	RPA 20	20	420/80	03.020
<p>RLY series - pilot operated spool-type. Very good stability, large ports for high flows and applications with wide range of reduced pressure regulation.</p>	RLY 30	40	420/210	03.030
	RLY 50	90	420/210	03.040
	RLY 70	160	420/210	03.050
<p>RLD series - direct acting spool-type. Have the same features of reducing pressure valves series RPA 20, but they act as pressure relief valves with flow from 3 to 1.</p>	RLD 20	16	420/80	03.060
<p>RLP series - pilot operated spool-type. Have the same features of reducing pressure valves series RLY, but they act as pressure relief valves with flow from 3 to 1.</p>	RLP 30	40	420/210	03.070
	RLP 50	90	420/210	03.080
	RLP 70	160	420/210	03.090

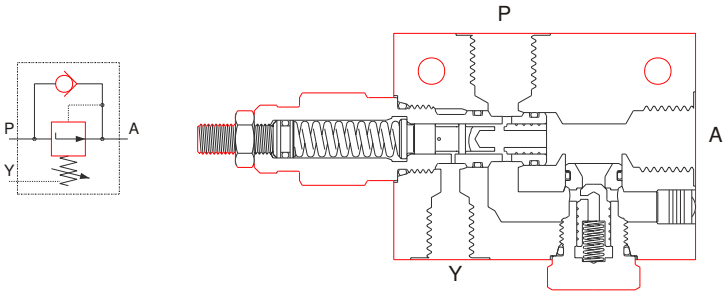
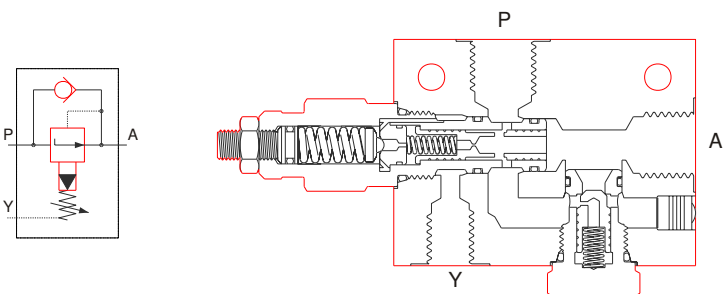
Main features	Type	Q max. (l/min.)	P / Pr (bar)	Technical schedule
<p>RPA 20 series CSL 11 circuit. They are assembled in one body and combined with one check valve which allows the freflow itself to move in direction from A to P.</p> 	<p>RPA 20 CSL 11</p>	<p>20</p>	<p>420/90</p>	<p>03.100</p>
<p>RLY series CSL 11 circuit. They are assembled in one body and combined with one check valve which allows the free-flow itself to move in direction from A to P.</p> 	<p>RLY 30 CSL 11</p>	<p>40</p>	<p>420/210</p>	<p>03.110</p>
<p>RLY 50 CSL 11</p>	<p>90</p>	<p>420/210</p>	<p>03.120</p>	
<p>RLY 70 CSL 11</p>	<p>160</p>	<p>420/210</p>	<p>03.130</p>	

Sequence and unloading valves, secondary-pressure insensitive.

They are manufactured in different models suitable for unloading or sequence functions; the LPQ and LPY types are used in many applications where pressures addition is not allowed.

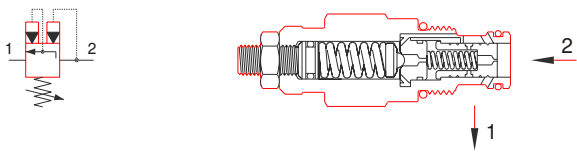
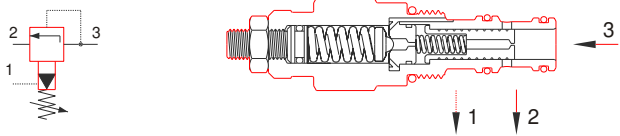
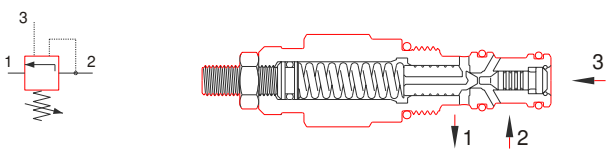

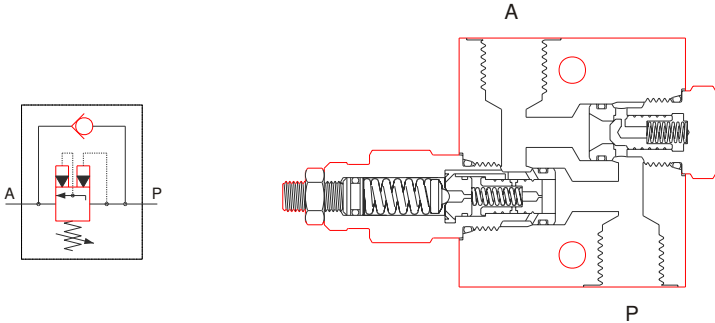
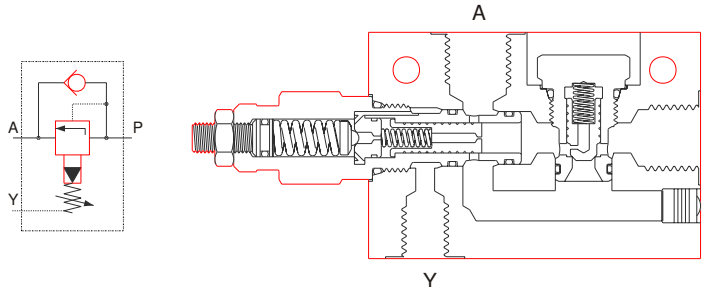
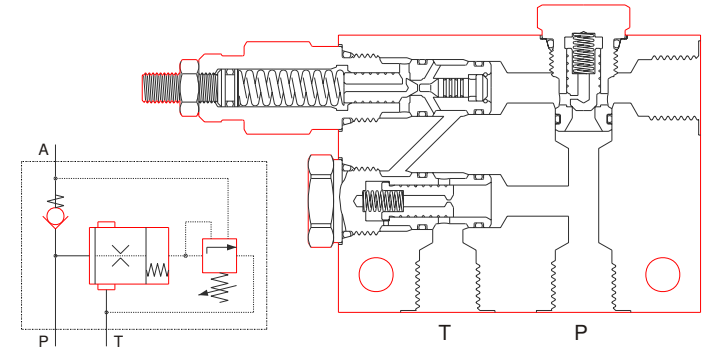
Main features	Type	Q max. (l/min.)	P max. (bar)	Technical schedule
<p>LPQ series - pilot operated spool-type. Are used to unload a line under pressure or as sequence valve. At setting pressure achievement the valve opens itself allowing the free passage with a very low pressure drop. The valve closes when pressure falls under a 7 bar value.</p> 	LPQ 30	70	420	04.010
	LPQ 50	160	420	04.020
	LPQ 70	320	420	04.030
<p>LPY series - pilot operated spool-type. Relief pilot operated valves with external drain. The line 1 (drain), directly connected with return line (T), makes the valve unsensitive to pressure of chamber 2 allowing to maintain the valve's setting and features.</p> 	LPY 30	70	420	04.040
	LPY 50	160	420	04.050
	LPY 70	320	420	04.060
<p>LCA 20 series - guided conical poppet-type.</p> <p>Differential Area Unloading relief valves, are mainly used to charge accumulators or for pump unloading in high-low pressure circuits.</p> <p>They allow the automatic pump's by-pass as the circuit pressure reaches the setting value. The valve closes when this value drops at 87% and pump starts charging the accumulator.</p> <p>The valve LCA 20 series must be combined with logical elements of ELP series, version P1 or similar; they may be used assingle unit only thanks to special devices. For advice please ask our technical department.</p> 	LCA 20	3	210	04.070

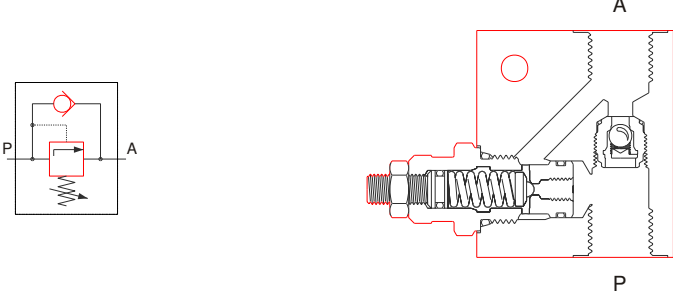
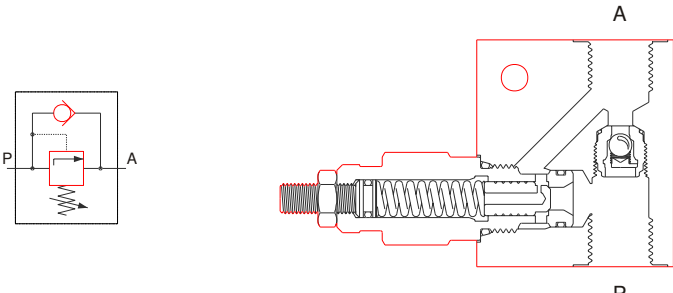
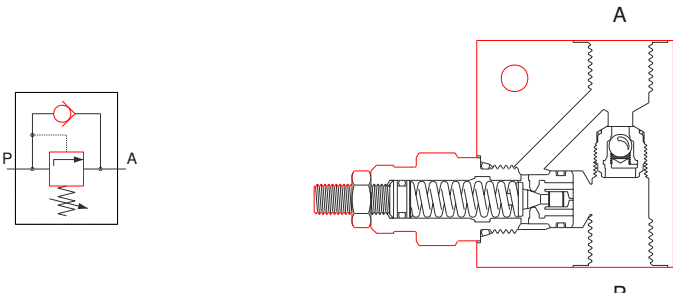
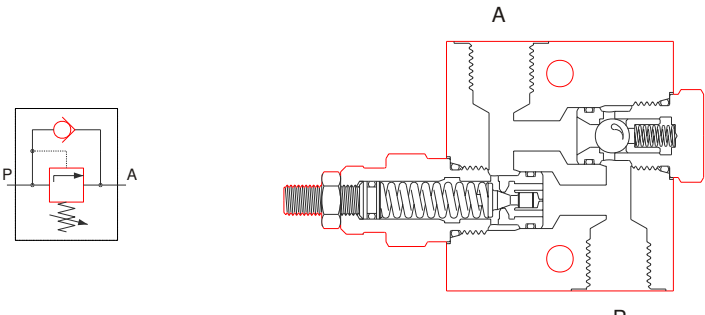
Main features	Type	Q max. (l/min.)	P max. (bar)	Technical schedule
<p>LPQ series CSL 10 circuits. They are used as sequence valves. At reaching the setting value, the valve opens and allows the fluid free-flow passage. When pressure drop under a value lower than 7 bar, the valve closes again. The annexed by-pass valve allows the free-flow in direction from A to P.</p> 	<p>LPQ 30 CSL 10</p>	70	420	04.080
	<p>LPQ 50 CSL 10</p>	160	420	04.090
	<p>LPQ 70 CSL 10</p>	320	420	04.100
<p>LPY series CSL 10 circuits. They are sequence pilot operated valves with external drain. The line Y (drain line) which is directly connected with return line (T), makes the valve indifferent to port A pressure, keeping the setting features unchanged. The annexed by-pass valve allows the free-flow in direction from A to P.</p> 	<p>LPY 30 CSL 10</p>	70	420	04.110
	<p>LPY 50 CSL 10</p>	160	420	04.120
	<p>LPY 70 CSL 10</p>	320	420	04.130
<p>DPA series These valves are used to unloading a pump once a certain pressure has been reached in the main circuit. They are either used an accumulator circuit unload the pump when the accumulator charge pressure has been reached or in a two pump circuit to unload the low pressure pump.</p> 	<p>DPA 30</p>	60	210	04.140
	<p>DPA 50</p>	135	210	04.142
	<p>DPA 70</p>	300	210	04.144

Main features	Type	Q max. (l/min.)	P max. (bar)	Technical schedule
<p>LPS 20/ 20 series CSL 10 circuit. They are a simple unexpansive version for high pressure applications. Ideal solution for narrow flows, they have got a very good oiltight with total pressure peak absence. The pressure required from secondary circuit adds to the setting pressure and the by-pass valve allows the flow free-return with direction from A to P.</p> 	<p>LPS 20/ 20 CSL 10</p>	<p>12</p>	<p>420</p>	<p>04.150</p>
<p>LPE 20 series CSL 10 circuit. They have the same body of LPS 20 series, moreover the use of valves LPE 20 series guarantees a better flow-pressure trend.</p> 	<p>LPE 20 CSL 10</p>	<p>20/30</p>	<p>210</p>	<p>04.155</p>
<p>LPA 20 series CSL 10 circuit. They have the same body of LPS 20 series, moreover the use of valves LPA 20 series guarantees a better flow-pressure trend.</p> 	<p>LPA 20 CSL 10</p>	<p>20</p>	<p>350</p>	<p>04.160</p>
<p>LPA 30 series CSL 10 circuit. The use of valve size 30 makes this series suitable for flows till 50 l/min. This series uses the same body of valve LPQ 30 - CSL 10.</p> 	<p>LPA 30 CSL 10</p>	<p>50</p>	<p>350</p>	<p>04.170</p>

Check valves.

The check valves are available into two different executions: ball-type and poppet-type.
The first one is an unexpensive version suitable for light uses, while the second one version with pilot piston offers larger lasting and good oiltight guarantee.

Main features	Type	Q max. (l/min.)	P max. (bar)	Technical schedule
<p>CB series - ball-type. They are little check valves, suitable for easy execution of cavity setting. They have a very good oiltight and are mainly used in pilot systems and hydraulic installations with narrow flows.</p> 	CB 20/ D05	20	350	05.005
<p>CAB series - guided ball-type. They have a very good oiltight, are used as by-pass, anti-cavitation valves, on pump's turn or as check valves in circuits with average pressure and for duty-cycle work.</p> 	CAB 20	25	210	05.010
<p>CAE series - guided conical poppet-type. They have a very good oiltight, ideal solution for a continuous service with frequent flows reverse, high pressures and low pressure drop.</p> 	CAE 20	35	420	05.050
	CAE 30	60	420	05.060
	CAE 50	135	420	05.070
	CAE 70	300	420	05.080

Pilot check valves.

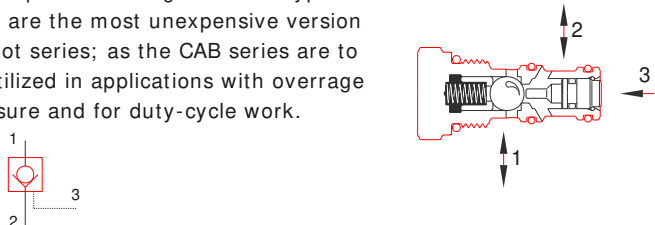
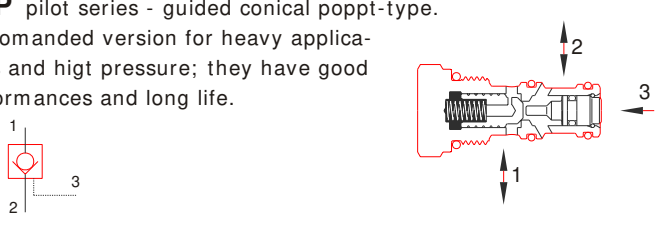
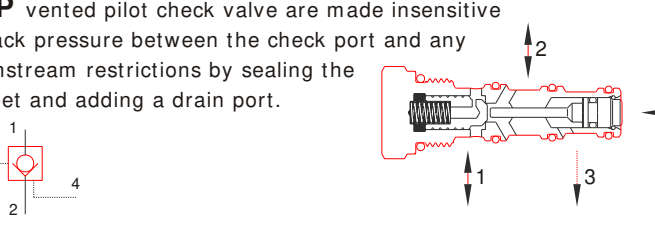
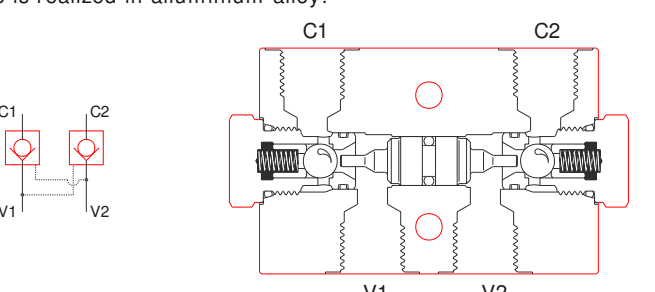
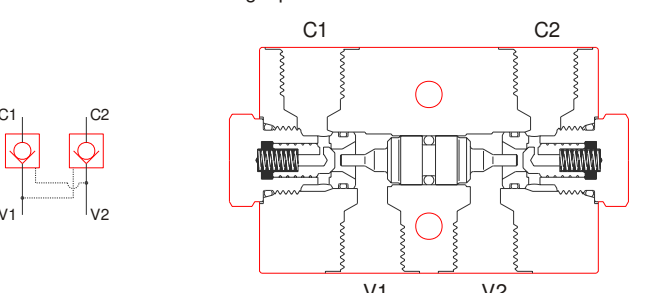

The directional pilot poppet-type valves are available into two executions: poppet-type and ball-type.
On piloting piston of every valves there is a seal which can be removed by request.
For pilot ratios and pressure drop see technical detailed schedules.

Main features	Type	Q max. (l/min.)	P max. (bar)	Technical schedule
<p>CAT pilot series - guided boll-type. They are the most unexpensive version of pilot series; as the CAB series are to be utilized in applications with overvage pressure and for duty-cycle work.</p> 	CAT 20	20	210	05.090
	CAT 30	35	210	05.091
<p>CAP pilot series - guided conical poppt-type. Reccomanded version for heavy applica- tions and high pressure; they have good performances and long life.</p> 	CAP 20	30	350	05.100
	CAP 30	50	350	05.110
	CAP 50	100	350	05.120
<p>CDP vented pilot check valve are made insensitive at back pressure between the check port and any downstream restrictions by sealing the poppet and adding a drain port.</p> 	CDP 30	50	350	05.150
<p>CAB ..-CSL 57 series - guided ball-type. They have a very good oiltight but limited performances; are used in average pressure circuits and for light duty-cycle work, the body valve is realized in alluminium alloy.</p> 	CAB 20/ CSL 57	20	210	05.200
	CAB 30/ CSL 57	35	210	05.210
<p>CAE ..-CSL 57 series - guided conical poppet-type. They have a very good oiltight, ideal for continuous work with frequent flow reverse and high pressures.</p> 	CAE 20/ CSL 57	30	350	05.220
	CAE 30/ CSL 57	50	350	05.230
	CAE 50/ CSL 57	100	350	05.240

Shuttle valves.

The shuttle valves are available in different executions and accomplish many circual functions.

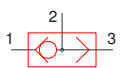
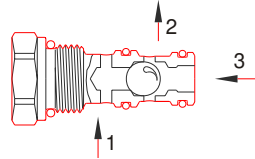
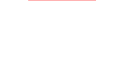
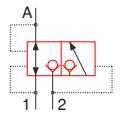
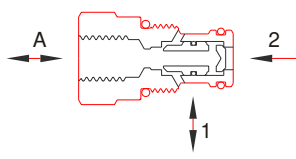
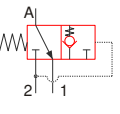
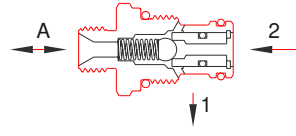
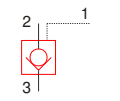
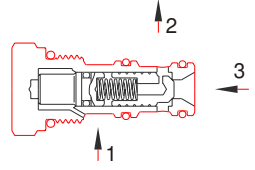
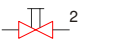
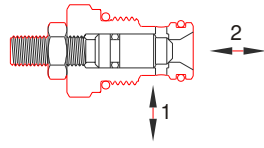
The guided ball or poppet type guarantees a perfect oiltight; these valves are used in piloting distributors and valves' systems, in hydraulic brakes automatic release system and in unit power.

Main features	Type	Q max. (l/min.)	P max. (bar)	Technical schedule		
CCI series - guided ball-type. They are shuttle valves with two way-in and one way-out. The high pressure way-in is always automatically connected with the way-out, while the second way-in keeps tight closed.			CCI 20	25	350	05.300
				CCI 30	50	350
CCE series - guided conical poppet-type. They have a very good oiltight, ideal for hydraulic brakes control. The return line of port A always happens through line 1.			CCE 20	16	210	05.320
CDE series - guided poppet-type. The shuttle valves and the unloading valves are a very simplify version of directional automatic valve. The inlet flow happens through chamber 2 and flow is automatically sent to port A; when the flow from chamber 2 stops there is the commutation and the retourn line of port A happens through line 1.			CDE 20	16	210	05.330
CPA series - pilot to closed, guided conical poppet-type. They are pilot to closed check valves normally open in one direction; they close when enough pressure is apply on piloting line.			CPA 30	50	350	05.350
RMB series. They are manual valves total shut off with conical seat. Also available with handknob control, can be used as choker when a fine regulation is non required. The flow direction is indifferent.			RMB 20	50	315	05.520
			RMB 30	100	315	05.530
			RMB 50	150	315	05.540

Directional spool-type valves.

They are spool-type valves thought of to change over automatically the flow direction in relation to piloting. Available in two different executions they satisfy many needs simplifying the hydraulic circuits realization.

Main features	Type	Q max. (l/min.)	P max. (bar)	Technical schedule
VDT ../ 3203 series. They are a fixed setting version typically used for regenerative circuits realization or as automatic selector valve combined with solenoid poppet-type valves for single acting cylinders control.	VDT 20/ 3203	25	350	05.600
	VDT 30/ 3203	50	350	05.610
	VDT 50/ 3203	100	350	05.620
VDT 20/ 3203-IB series. They are a version which contemplates the regulation for pressure setting.	VDT 20/ 3203	25	350	05.601 05.605
VDT ../ 3306 series. Shuttle valves for hydrostatic transmissions in closed circuits.	VDT 30/ 3306	40	420	05.650
VDT ../ 3201 series - normally open. Hydraulic pilot directional valves adjusting through a connected atmospherical pressure spring, indifferent to circuit's pressure.	VDT 20/ 3201	25	350	05.670
	VDT 30/ 3201	50	350	05.690
VDT ../ 3202 series - normally closed. Hydraulic pilot directional valves adjusting through a connected atmospherical pressure spring, indifferent to circuit's pressure.	VDT 20/ 3202	25	350	05.670
	VDT 30/ 3202	50	350	05.690

Main features	Type	Q max. (l/min.)	P max. (bar)	Technical schedule
<p>VDT ../ 4203 series - shuttle valves. Hydraulic pilot directional valves adjusting through a connected atmospheric pressure spring, indifferent to circuit's pressure.</p>	VDT 20/ 4203	25	350	05.740
	VDT 30/ 4203	50	350	05.750
<p>VDT ../ 4205 series. Directional shuttle valves with external hydraulic pilot.</p>	VDT 20/ 4205	20	350	05.780
	VDT 30/ 4205	40	350	05.790
<p>VDT ../ 4211 series. Directional valves with external hydraulic pilot for regenerative circuit.</p>	VDT 20/ 4211	20	350	05.780
	VDT 30/ 4211	40	350	05.790
<p>VDT ../ 3204-PS series. Manual directional control valves for pressure gauge.</p>	VDT 20/ 3204-PS	20	350	05.810

Many other circuits are available on request.

Flow control valves.

They can be classified as needle valves or as compensated flow controls two or three way; are used to keep a check on actuators speed, to share out the flow or as fuse valves.

Main features	Type	Q max. (l/min.)	P max. (bar)	Technical schedule
RDB series - bidirectional poppet-type. They have a very fine adjustment which allows to control also narrow flow at high pressure in both the flow's directions. Completely closed they guarantee a perfect shut off.	RDB 20	20	350	06.011
	RDB 30	50	350	06.020
RDA series - with reverse free flow check poppet-type. They allow the flow's control in direction 2 - 1; the reverse flow is free. Even if perfectly closed it's not shut off.	RDA 20	30	350	06.030
	RDA 30	60	350	06.040
RDC series - two-way pressure compensated valves. They keep the flow adjusted uniform independently from the pressure and accept a reverse limited flow in relation to the required adjusting range.	RDC 20	18	315	06.050
	RDC 30	45	315	06.060
	RDC 50	60	315	06.080
RDZ series - two-way pressure compensated valves. They keep the flow adjusted uniform independently from the pressure. The peculiar feature of these vales is the high sensitive adjusting obtained with 1 knob turn and without effort.	RDZ 30	24	315	06.070

Flow control valves.

They can be classified as needle valves or as compensated flow controls two or three way; are used to keep a check on actuators speed, to share out the flow or as fuse valves.

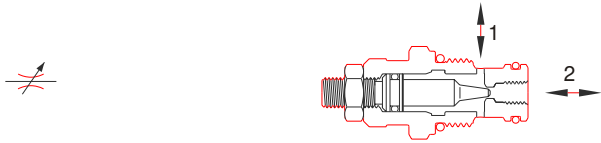
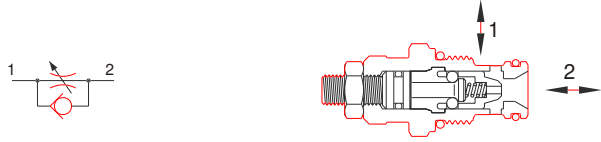
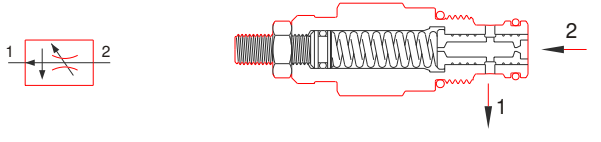
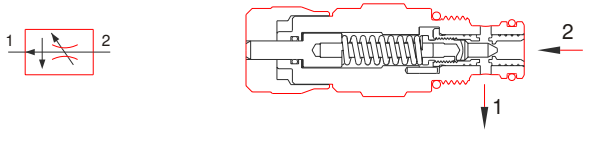
Main features	Type	Q max. (l/min.)	P max. (bar)	Technical schedule
<p>RDB series - bidirectional poppet-type. They have a very fine adjustment which allows to control also narrow flow at high pressure in both the flow's directions. Completely closed they guarantee a perfect shut off.</p> 	RDB 20	20	350	06.011
	RDB 30	50	350	06.020
<p>RDA series - with reverse free flow check poppet-type. They allow the flow's control in direction 2 - 1; the reverse flow is free. Even if perfectly closed it's not shut off.</p> 	RDA 20	30	350	06.030
	RDA 30	60	350	06.040
<p>RDC series - two-way pressure compensated valves. They keep the flow adjusted uniform independently from the pressure and accept a reverse limited flow in relation to the required adjusting range.</p> 	RDC 20	18	315	06.050
	RDC 30	45	315	06.060
	RDC 50	60	315	06.080
<p>RDZ series - two-way pressure compensated valves. They keep the flow adjusted uniform independently from the pressure. The peculiar feature of these vales is the high sensitive adjusting obtained with 1 knob turn and without effort.</p> 	RDZ 30	24	315	06.070

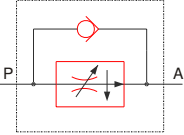
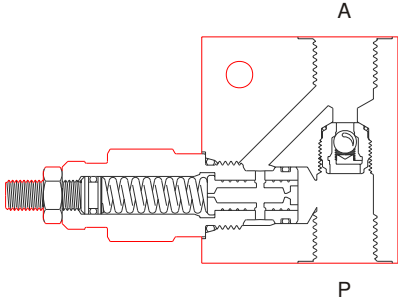
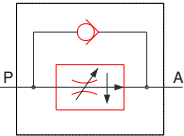
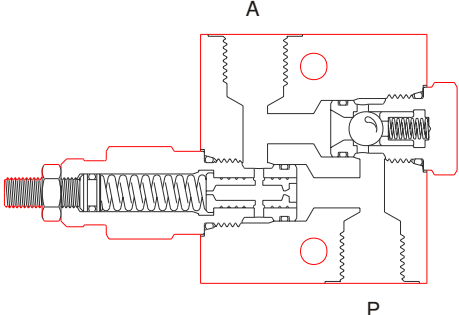
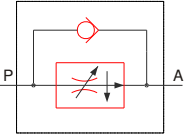
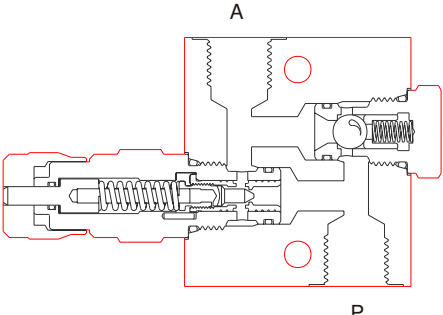
Main features	Type	Q max. (l/min.)	P max. (bar)	Technical schedule
<p>RDC series CSL 10 circuit.</p> <p>They are composed of a flow regulator pressure compencated RDC 20 type and a check valve that allows the free reverse flow.</p>  	<p>RDC 20 CSL 10</p>	<p>20</p>	<p>315</p>	<p>06.180</p>
<p>RDC series CSL 10 circuit.</p> <p>They are composed of a flow regulator pressure compencated RDC 30 type and a check valve that allows the free reverse flow.</p>  	<p>RDC 30 CSL 10</p>	<p>45</p>	<p>315</p>	<p>06.190</p>
<p>RDZ series CSL 10 circuit.</p> <p>They are composed of a flow regulator pressure compencated RDZ 30 type and a check valve that allows the free reverse flow.</p>  	<p>RDZ 30 CSL 10</p>	<p>24</p>	<p>315</p>	<p>06.200</p>

Motion control or overcenter valves.

As primary function these motion control or overcenter valves control the actuators' speed in relation to inlet flow, keep them blocked up, prevent pressure uncontrollable increases and avoid cavitation during movements. If placed directly on actuators they also guarantee the pipe's safety.

Main features	Type	Q max. (l/min.)	P max. (bar)	Technical schedule
CMS series - without by-pass valve. Are used in all circuits where in addition to overcenter function, is also required a control of load induced pressure. The by-pass valve must be externally set.	CMS 20	50	350	07.010
	CMS 30	90	350	07.020
	CMS 50	160	350	07.030
	CMS 70	360	350	07.040
CMQ series - with internal by-pass valve. Are used in all circuits where the only motion or overcenter function is required. The internal by-pass valve allows the free flow in direction from 1 to 2.	CMQ 30	50	350	07.060
	CMQ 50	90	350	07.070
CMC series - with internal by-pass valve. It is a version provided with an atmospheric pressure connected spring. The setting value remain unchanged also with back pressure in chamber 1. The internal by-pass valve allows the free flow in direction from 1 to 2.	CMC 30	50	350	07.100
	CMC 50	90	350	07.110
CMQ series CSL 25 circuit They are two overcenter valves combined in a special manifold for double acting function.	CMQ 30/ CSL 25	50	350	07.200
	CMQ 50/ CSL 25	90	350	07.210

Pilot operated solenoid valves poppet-type (210 bar).

These are two-ways pilot operated solenoid valves with conical poppet-type, manufactured in several sizes and with different circuits. They can be used in applications where leakages are not allowed.

The ECP series, which uses 18 Watt low power coils, is suitable for working at max. pressure of 210 bar.

The duty current coils (12-24 Volt) can be directly fed; otherwise for alternate current coils (24-110-220 Volt 50/60 Hz) a connector with rectifier bridge is required, which can be supplied on request.

Main features	Type	Q max. (l/min.)	P max. (bar)	Technical schedule
ECP../ 22C1 series - unidirectional type. Normally open, they stop the flow passage from 1 to 2 when energized; the reverse flow is not allowed.	ECP 20/ 22C1	30	210	08.010
	ECP 30/ 22C1	50	210	08.020
	ECP 50/ 22C1	90	210	08.030
ECP../ 22B1 series - bidirectional type. Normally open, they stop the flow passage from 1 to 2 when energized; the reverse flow is allowed in any condition.	ECP 20/ 22B1	30	210	08.010
	ECP 30/ 22B1	50	210	08.020
	ECP 50/ 22B1	90	210	08.030
ECP../ 22C2 series - unidirectional type. Normally closed, they allow the flow passage from 1 to 2 when energized; the reverse flow is allowed only with de-energized coil.	ECP 20/ 22C2	30	210	08.010
	ECP 30/ 22C2	50	210	08.020
	ECP 50/ 22C2	90	210	08.030
ECP../ 22B2 series - bidirectional type. Normally closed, they allow the flow passage from 1 to 2 when energized; the reverse flow is allowed in any condition.	ECP 20/ 22B2	30	210	08.010
	ECP 30/ 22B2	50	210	08.020
	ECP 50/ 22B2	90	210	08.030

Pilot operated solenoid valves poppet-type (350 bar).

These are two-way pilot operated solenoid valves with conical poppet-type, manufactured in several sizes and with different circuits. They can be used in applications where leakages are not allowed.

The EPP series, which uses 28 Watt power coils, is suitable for working till 350 bar.

The duty current coils (12-24 Volt) can be directly fed; otherwise for alternate current coils (20-110-220 Volt 50/60 Hz) a connector with rectifier bridge is required, which can be supplied on request.

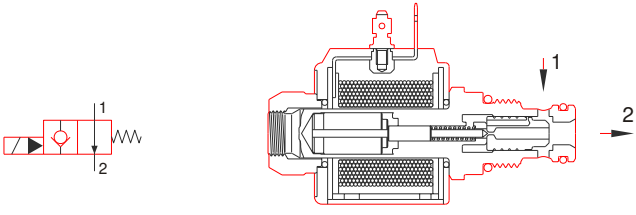
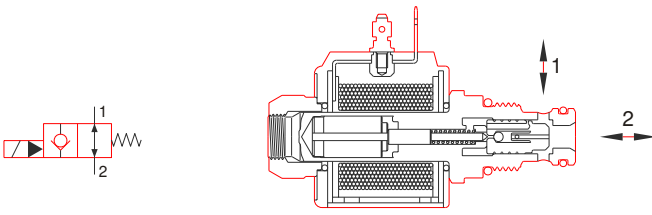
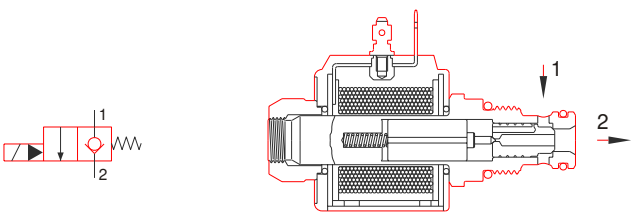
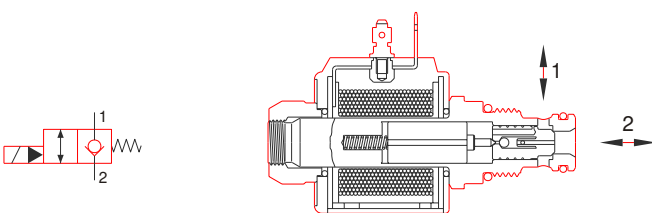
Main features	Type	Q max. (l/min.)	P max. (bar)	Technical schedule
<p>EPP../ 22C1 series - unidirectional type. Normally open, they stop the flow passage from 1 to 2 when energized; the reverse flow is not allowed.</p> 	EPP 30/ 22C1	60	350	08.040
	EPP 50/ 22C1	100	350	08.050
	EPP 70/ 22C1	200	350	08.060
<p>EPP../ 22B1 series - bidirectional type. Normally open, they stop the flow passage from 1 to 2 when energized; the reverse flow is allowed in any condition.</p> 	EPP 30/ 22B1	60	350	08.040
	EPP 50/ 22B1	100	350	08.050
	EPP 70/ 22B1	200	350	08.060
<p>EPP../ 22C2 series - unidirectional type. Normally closed, they allow the flow passage from 1 to 2 when energized; the reverse flow is allowed only with de-energized coil.</p> 	EPP 30/ 22C2	60	350	08.040
	EPP 50/ 22C2	100	350	08.050
	EPP 70/ 22C2	200	350	08.060
<p>EPP../ 22B2 series - bidirectional type. Normally closed, they allow the flow passage from 1 to 2 when energized; the reverse flow is allowed in any condition.</p> 	EPP 30/ 22B2	60	350	08.040
	EPP 50/ 22B2	100	350	08.050
	EPP 70/ 22B2	200	350	08.060

Pilot solenoid valves poppet-type (210 bar).

These are two-way direct solenoid valves with conical poppet-type, manufactured only in size 20 and with different circuits; are mainly used as pilot valves in oiltight systems.

The ECD 20 series, which uses 18 Watt low power coils, is suitable for working at max. pressure of 210 bar.

The duty current coils (12-24 Volt) can be directly fed; otherwise for alternate current coils (20-110-220 Volt 50/60 Hz) a connector with rectifier bridge is required, which can be supplied on request.

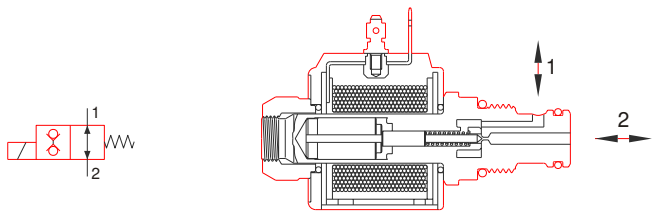
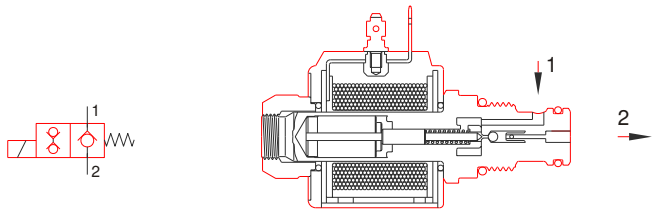
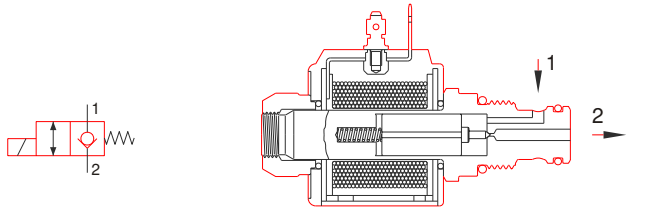
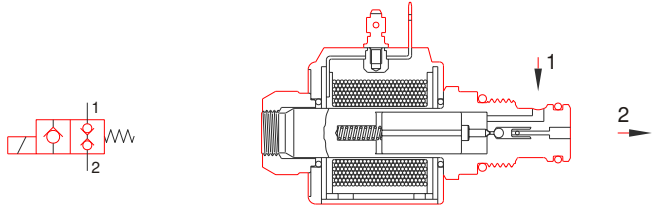
Main features	Type	Q max. (l/min.)	P max. (bar)	Technical schedule
<p>22B1 series - bidirectional type. On rest position, they allow free passage and stop it in both directions when energized.</p> 	ECD 20/ 22B1	1.2	210	08.070
<p>22U1 series - unidirectional type. Normally open, they allow flow passage from 1 to 2; when energized they stop it in both directions.</p> 	ECD 20/ 22U1	1.2	210	08.070
<p>22B2 series - bidirectional type. Normally closed, when energized they allow flow passage in both directions. The flow from 2 to 1 is allowed only high pressure (see catalogue).</p> 	ECD 20/ 22B2	1.2	210	08.070
<p>22U2 series - unidirectional type. Normally closed, when energized they allow flow passage from 1 to 2 and stop the reverse flow in any condition.</p> 	ECD 20/ 22U2	1.2	210	08.070

Direct acting solenoid valves dual poppet-type.

These are two and three way direct acting valves with conical poppet-type, manufactured in sizes 20-30 and 50 and in several circuit; are used in applications where leakages are not allowed.

The solenoid ECD series utilize power coils and are suitable for working till 315 bar.

The duty current coils (12-24 Volt) can be directly fed; otherwise for alternate current coils (24-110-220 Volt 50/60 Hz) a connector with rectifier bridge is required, which can be supplied on request.

Main features	Type	Q max. (l/min.)	P max. (bar)	Technical schedule
ECD../ 2201 series - bidirectional type. Normally open, when energized they stop the flow passage in both directions.	ECD 30/ 2201	20	315	08.080
	ECD 50/ 2201	40	315	08.090
ECD../ 2202 series - bidirectional type. Normally closed in both directions, when energized they allow the flow free passage.	ECD 20/ 2202	10	210	08.075
	ECD 30/ 2202	25	315	08.080
	ECD 50/ 2202	50	315	08.090
ECD../ 3204 series - switching over type. They allow to switch over the flow, tight insulating chamber 1 or 3 by turns. The flow is allowed in all directions.	ECD 20/ 3204	10	210	08.095
	ECD 30/ 3204	25	315	08.100
	ECD 50/ 3204	50	315	08.110
ECD../ 3204S series. Normally closed, they allow to drive a simple effect cylinder connecting 3 with pump, 2 with cylinder and 1 with return line (T).	ECD 30/ 3204S	20	315	08.100

Single solenoid valves.

They are simple solenoid valves with two, three and four way, manufactured in sizes 20, 30 and 50 and in several circuits, are used in compact applications settled in manifolds.

The solenoid ETD series utilize power coils and are suitable for working till 315 bar.

The duty current coils (12-24 Volt) can be directly fed; otherwise for alternate current coils (24-110-220 Volt 50/60 Hz) a connector with rectifier bridge is required, which can be supplied on request.

Main features	Type	Q max. (l/min.)	P max. (bar)	Technical schedule
ETD../ 22.. series - two-ways type. Normally open or closed, have better performances with flow from 1 to 2, in the opposite direction it's necessary to limit flow. 	ETD 20/ 2201	15	210	09.010
	ETD 30/ 2201	30	315	09.020
	ETD 50/ 2201	60	315	09.030
	ETD 20/ 2202	15	210	09.010
	ETD 30/ 2202	30	315	09.020
	ETD 50/ 2202	60	315	09.030
ETD../ 32.. series - three-way type. Manufactured with two different circuits in order to obtain highest performances. With flow direction oppoist to symbols it's necessary to limit flow and max. pressure. 	ETD 20/ 3203	15	210	09.040
	ETD 30/ 3203	30	315	09.050
	ETD 50/ 3203	60	315	09.060
	ETD 20/ 3204	15	210	09.040
	ETD 30/ 3204	30	315	09.050
	ETD 50/ 3204	60	315	09.060
ETD../ 42.. series - four-way type centre closed. 	ETD 20/ 4205	15	315	09.070
	ETD 30/ 4205	30	315	09.080
	ETD 50/ 4205	60	315	09.090
	ETD 20/ 4206	15	315	09.070
	ETD 30/ 4206	30	315	09.080
	ETD 50/ 4206	60	315	09.090
ETD../ 42.. series - four-way type centre open. 	ETD 20/ 4207	12	315	09.100
	ETD 30/ 4207	25	315	09.110
	ETD 50/ 4207	45	315	09.120
	ETD 20/ 4208	12	315	09.100
	ETD 30/ 4208	25	315	09.110
	ETD 50/ 4208	45	315	09.120

Duble solenoid valves.

They are duple solenoid valves with four-way and three-positions, manufactured in sizes 20, 30 and 50 and in several circuits; are used in pilot systems and compact applications settled in manifolds.

The solenoid ETD series utilize power coils and are suitable for working till 315 bar.

The duty current coils (12-24 Volt) can be directly fed; otherwise for alternate current coils (24-110-220 Volt 50/60 Hz) a connector with rectifier bridge is required, which can be supplied on request.

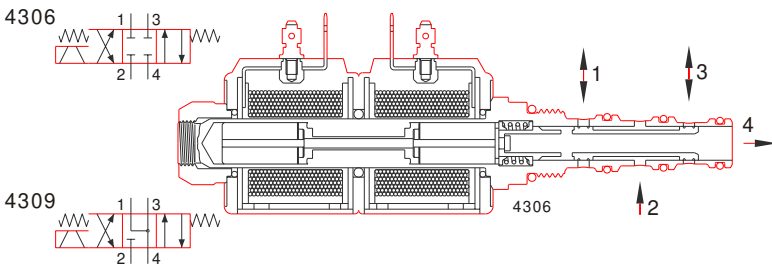
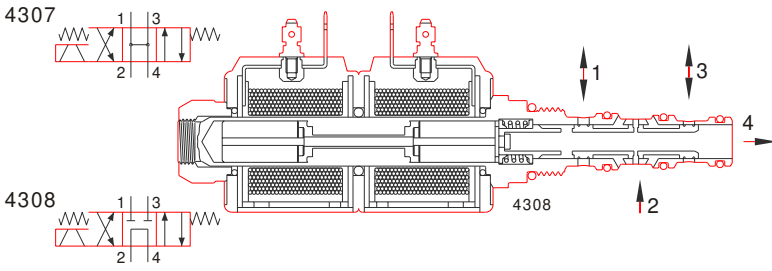
Main features	Type	Q max. (l/min.)	P max. (bar)	Technical schedule
ETD../ 43.. series - four-way type centre closed. 	ETD 20/ 4306	15	315	09.130
	ETD 30/ 4306	30	315	09.140
	ETD 50/ 4306	60	315	09.150
	ETD 20/ 4309	15	315	09.130
	ETD 30/ 4309	30	315	09.140
	ETD 50/ 4309	60	315	09.150
ETD../ 42.. series - four-way type centre open. 	ETD 20/ 4307	12	315	09.160
	ETD 30/ 4307	25	315	09.170
	ETD 50/ 4307	45	315	09.180
	ETD 20/ 4308	12	315	09.160
	ETD 30/ 4308	25	315	09.170
	ETD 50/ 4308	45	315	09.180

Special circuits supplied on request.

On Customers request and for large quantity, solenoid valves with not standard circuits can be supplied. The circuits under mentioned are models already manufactured.

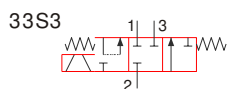
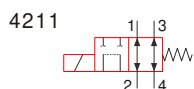
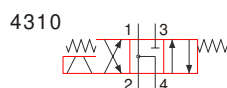
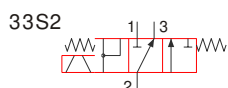
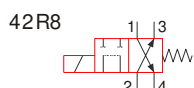

Pressure relief valves.

These are proportional solenoid valves manufactured in several sizes and with different functions. They distinguish themselves for their good peculiar features and their first rate connection between quality and price.

The special constructive shape allows the first setting regulation range during the assembling phase with an infinitude of regulation chances. They can be indifferently assembled with Flucom's Electronic Card or with any other normalized.

Main features	Type	Q max. (l/min.)	P max. (bar)	Technical schedule
<p>PPS 20 series - direct acting type. Normally used for piloting dual stage valves, this pilot valve is available only in size 20 and with several regulation ranges.</p>	PPS 20/ ...	1.5	350	10.010
<p>PPI series - pilot operated type. Pilot operated valves, available in several sizes and with different regulation ranges, are normally used for proportional pressure change in installations with high flows.</p>	PPI 30/ ...	70	350	10.020
	PPI 50/ ...	160	350	10.030
	PPI 70/ ...	320	350	10.040
<p>PPY series - pilot operated type. Pilot operated valves, available in several sizes and with different regulation ranges, are not sensitive to possible back pressures thanks to drain line 1 which is independently connected with return line (T).</p>	PPY 30/ ...	70	350	10.050
	PPY 50/ ...	160	350	10.060
	PPY 70/ ...	320	350	10.070

Pressure reducing valves.

These are proportional pressure reducing valves manufactured in several sizes, acting as reducing or reducing-relieving valve. They distinguish themselves for their first rate connection between quality and price.

The special constructive shape allows the first setting regulation range during the assembling phase with an infinitude of regulation chances. They can be indifferently assembled with Flucom's Electronic Card or with any other normalized.

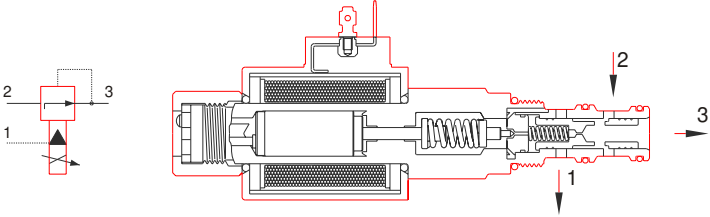
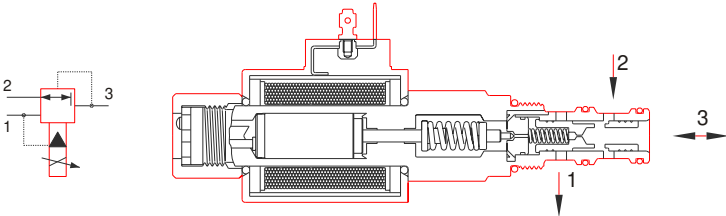
Main features	Type	Q max. (l/min.)	P max. (bar)	Technical schedule
<p>PLY series - pilot operated type.</p> <p>Pilot operated valves available in several sizes and with different regulation ranges, are normally used as unidirectional proportional pressure reducing valves.</p> 	PLY 30/ ...	40	420/210	10.080
	PLY 50/ ...	90	420/210	10.090
	PLY 70/ ...	160	420/210	10.100
<p>PLP series - pilot operated type.</p> <p>They have the same features of PLY series but in addition they act as pressure relief valve with flow from 3 to 1.</p> 	PLP 30/ ...	40	420/210	10.130
	PLP 50/ ...	90	420/210	10.140
	PLP 70/ ...	160	420/210	10.150

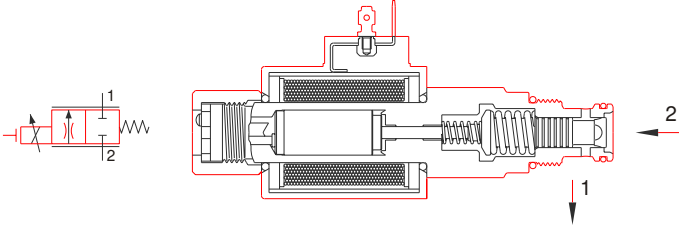
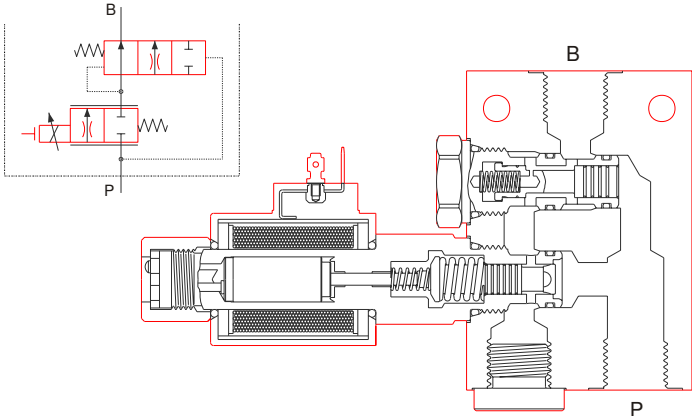
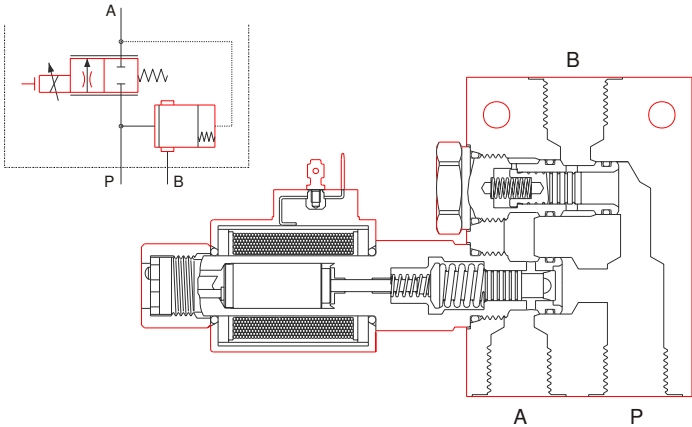

Flow controls.

Proportional solenoid valves PSS series are flow regulator not compensated, normally closed, which is controlled by a remote electronic card. While the valve is not energized the flow in both directions is not allowed. Operating on potentiometer through electronic card allow to act on proportional solenoid and it's possible to obtain an infinitude of different regulations with great precision and repeatability.

Main features	Type	Q max. (l/min.)	P max. (bar)	Technical schedule
<p>PSS series Direct acting are available with two range of adjustment; are provided with a manual override on back side and a screw for the initial air vent-hole.</p>  <p>The diagram shows a schematic of a direct-acting proportional solenoid valve with two ports labeled 1 and 2. The cross-section shows the internal solenoid coil, a spool, and a spring mechanism. Port 1 is at the bottom and port 2 is at the right side.</p>	<p>PSS 30/ ...</p>	<p>30/60</p>	<p>315</p>	<p>10.160</p>
<p>PPQ 30/ 2.. series Pressure compensated proportional two way flow regulator normally closed. This combination valve uses a PSS 30 proportional valve and an ELP 30/Q2 compensator.</p>  <p>The diagram shows a schematic of a pressure-compensated two-way flow regulator with ports P and B. The cross-section shows the internal PSS 30 valve and an ELP 30/Q2 compensator. Port P is at the bottom and port B is at the top.</p>	<p>PPQ 30/ 2..</p>	<p>30/60</p>	<p>315</p>	<p>10.170</p>
<p>PPQ 30/ 3.. series Pressure compensated proportional three way flow regulator that is by-pass style. This combination valve uses a PSS 30 proportional valve and an ELP 30/Q1 logic element.</p>  <p>The diagram shows a schematic of a pressure-compensated three-way flow regulator with ports P, A, and B. The cross-section shows the internal PSS 30 valve and an ELP 30/Q1 logic element. Port P is at the bottom, port A is at the bottom left, and port B is at the top.</p>	<p>PPQ 30/ 3..</p>	<p>30/60</p>	<p>315</p>	<p>10.180</p>

Electronic Controller.

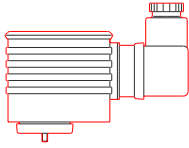
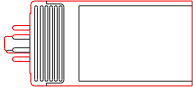
The proportional solenoid valves must be piloted only from an electronic card. Are available a normalized standard series of electronics components, on request are available also personalized complete systems.

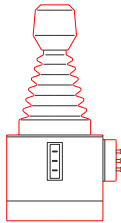
Type	Code	Voltage (Volt)	Functions	Technical schedule
VPC 	VPC-12-DIN	12	Connector DIN 43650 Minimum current set Maximum current set Rise ramp set Fall ramp set Dither External potentiometer	10.250
	VPC-24-DIN	24		
VPO 	VPO-12-OCTAL	12	Connector OCTAL 8 Minimum current set Maximum current set Rise ramp set Fall ramp set Dither External potentiometer	10.258
	VPO-24-OCTAL	24		
VPM 	VPM-12-D	12	Box Minimum current set Maximum current set Rise ramp set Fall ramp set Dither (optional) Integrated potentiometer	10.260
	VPM-24-D	24		
MEI - MEX 	MEI - M	12/24	One axis ON-OFF	10.800
	MEX - M	12/24	Two axis ON-OFF	10.800
	MEI - PM	12/24	One axis proportional	10.900
	MEX - PM	12/24	Two axis proportional	10.900

Pressure, flow and directional control logic valves.

These are logic elements used to pressure, flow and oiltight directional control. They are divided into two categories: as pressure and flow control they have a ratio between areas of 1:1; as directional control they have a ratio of 1:1.8. They always need piloting valves which acting on chamber 1, besides made them functioning, allow their regulation. The version used to flow control must be combined with a needle valve in order to breed a pressure drop of about 7 bar.

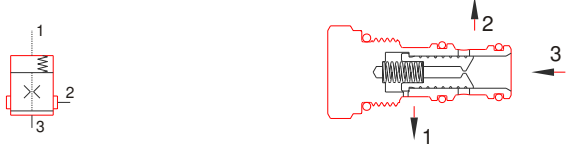
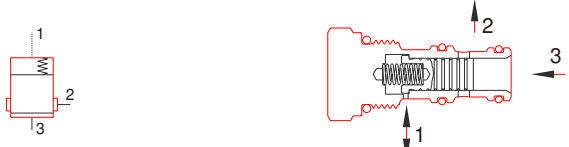
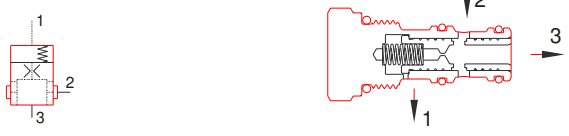
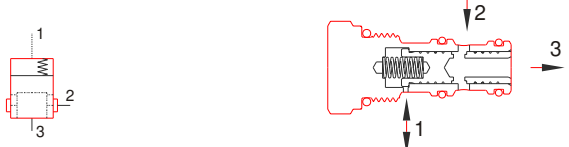
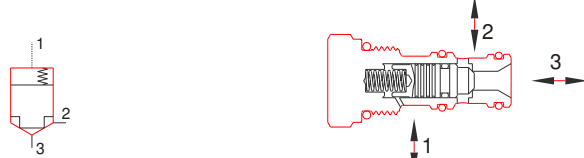
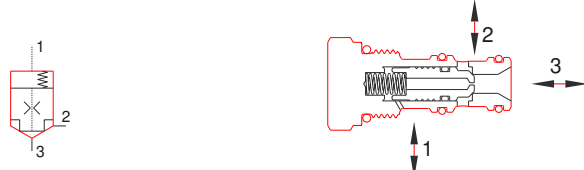
Main features	Type	Q max. (l/min.)	P max. (bar)	Technical schedule
ELP ../ P1 series - with area ratio 1:1 for pressure control. 	ELP 30/ P1	80	350	11.010
	ELP 50/ P1	160	350	11.020
	ELP 70/ P1	320	350	11.030
ELP ../ Q1 series - with area ratio 1:1 for flow control. 	ELP 30/ Q1	80	350	11.010
	ELP 50/ Q1	160	350	11.020
	ELP 70/ Q1	320	350	11.030
ELP ../ P3 series - with area ratio 1:1 to reduce pressure. 	ELP 30/ P3	50	350	11.040
	ELP 50/ P3	100	350	11.050
	ELP 70/ P3	200	350	11.060
ELP ../ Q3 series - with area ratio 1:1 for compensating flow control. 	ELP 30/ Q3	50	350	11.040
	ELP 50/ Q3	100	350	11.050
	ELP 70/ Q3	200	350	11.060
ELP ../ D2 series - with area ratio 1:1.8 for directional control. 	ELP 30/ D2	60	350	11.070
	ELP 50/ D2	120	350	11.080
	ELP 70/ D2	250	350	11.090
ELP ../ D3 series - with area ratio 1:1.8 for directional control. 	ELP 30/ D3	60	350	11.070
	ELP 50/ D3	120	350	11.080
	ELP 70/ D3	250	350	11.090

Special version supplied on request.

On request we can be supply following versions:

External adjusting for setting from 3.5 to 14 bar.
 Not standard calibrated holes.
 Priority compensators.
 Load sensing compensators.

These are valves in several sizes and functions, which do not belong to Flucom normalized range and stand out from the others owing to their different setting cavity dimensions. The series 32 (M 20x1.5) is in accordance with standardization of many European firms.

Main features	Type	Q max. (l/min.)	P max. (bar)	Technical schedule
<p>ECP 32/ 22C1-B1 Normally open, they stop flow passage from 1 to 2 when energized. The reverse flow is allowed only in version B1.</p>	<p>ECP 32/ 22C1 ECP 32/ 22B1</p>	30	210	12.100
<p>EPP-ECP 32/ 22C2-B2 Normally closed, they allow flow passage from 1 to 2 when energized. The reverse flow is allowed only in version B2.</p>	<p>EPP 32/ 22C2 EPP 32/ 22B2</p>	40	350	12.090
<p>ECD 32/ 2202 Normally closed in both directions, they allow the free passage flow when energized.</p>	<p>ECD 32/ 2202</p>	25	315	12.110

These are valves in several sizes and functions, which do not belong to Flucom normalized range and stand out from the others owing to their different setting cavity dimensions. The 28 and 29 series are in accordance with SAE standardization.

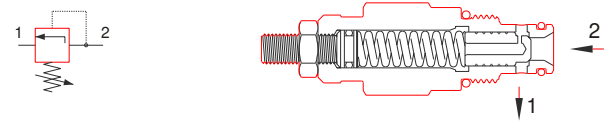
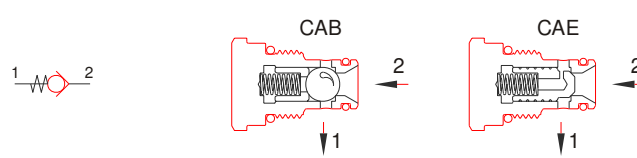
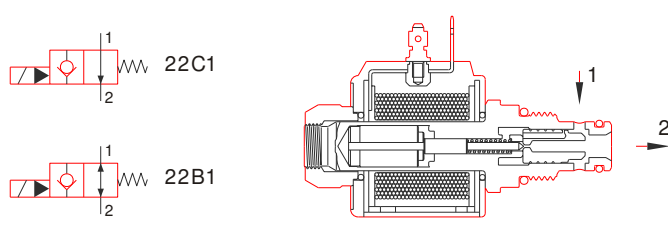
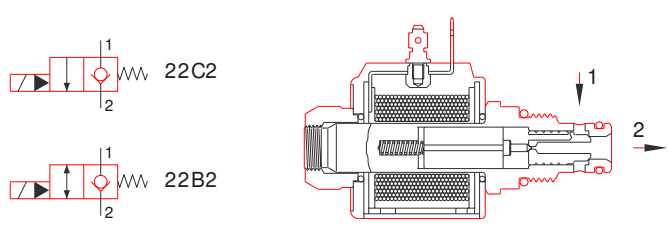
Main features	Type	Q max. (l/min.)	P max. (bar)	Technical schedule
<p>LPE 28 series - guided conical poppet-type. They have't a pressure peack, the pressure-flow trend is good. Generally are used as main pressure relief valve for continuous service or in dual cross-over valves in frequent intermittences applications.</p> 	LPE 28	30	210	12.130
<p>CAB 28 series, ball-type. CAE 28 series, guided conical poppet-type.</p> 	CAB 28	30	210	12.150
	CAE 28	40	420	12.151
<p>ECP 28/ 22C1-B1 Normally open, they stop flow passage from 1 to 2 when energized. The reverse flow is allowed only in version B1.</p> 	ECP 28/ 22 C1 ECP 28/ 22 B1	30	210	12.160 12.161
<p>ECP 28/ 22C2-B2 Normally closed, they allow flow passage from 1 to 2 when energized. The reverse flow is allowed only in version B2.</p> 	ECP 28/ 22 C2 ECP 28/ 22 B2	30	210	12.160 12.161

Main features	Type	Q max. (l/min.)	P max. (bar)	Technical schedule
<p>ECD 28/ 22..1 normally open.</p>	<p>ECD 28/ 22B1</p>	1.2	210	12.170
<p>ECD 28/ 22..2 normally closed.</p>	<p>ECD 28/ 22B2</p>	1.2	210	12.170
<p>ECD 28/ 22U1</p>	<p>ECD 28/ 22U1</p>	1.2	210	12.170
<p>ECD 29/ 2202 series - bidirectional type. Normally closed in both directions, when energized they allow the flow free passage.</p>	<p>ECD 29/ 2202</p>	10	210	08.180
<p>ECD 28/ 3204 series - switching over type. They allow to switch over the flow, tight insulating chamber 1 or 3 by turns. The flow is allowed in all directions.</p>	<p>ECD 28/ 3204</p>	5	210	12.190

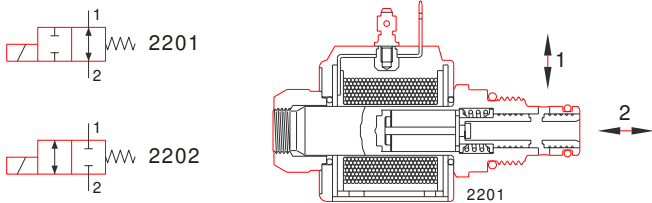
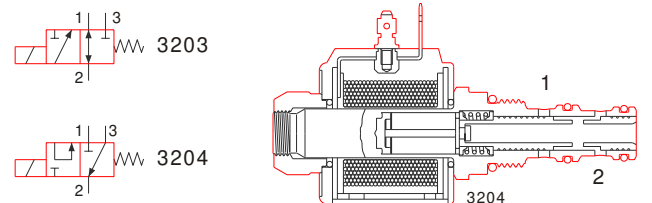
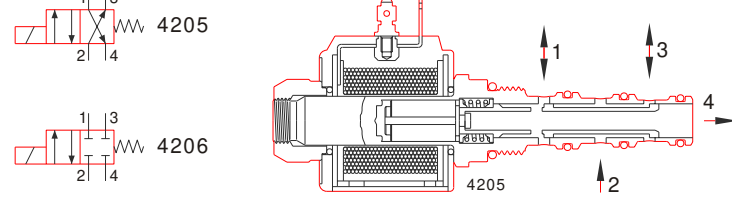
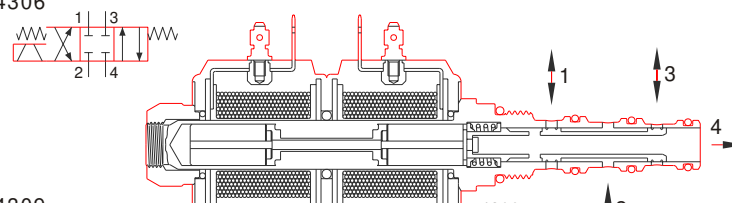
Main features	Type	Q max. (l/min.)	P max. (bar)	Technical schedule
<p>ETD 28/ 22.. series - two-ways type. Normally open or closed, have better performances with flow from 1 to 2, in the opposite direction it's necessary to limit flow.</p> 	ETD 28/ 2201	15	210	12.210
<p>ETD 28/ 32.. series - three-way type. Manufactured with two different circuits in order to obtain highest performances. With flow direction opposite to symbols it's necessary to limit flow and max. pressure.</p> 	ETD 28/ 3203	15	210	12.220
<p>ETD 28/ 42.. series - four-way type centre closed.</p> 	ETD 28/ 4205	15	315	12.230
<p>ETD 28/ 43.. series - four-way type centre closed.</p> 	ETD 28/ 4306	15	315	12.250
	ETD 28/ 4309	15	315	12.250

P and T line regulation and interception.

It is a series of blocks for sandwich assembling on connection surface CETOP R35 H-4.2-4-03, available in several executions for two or three way valve size 20 and 30, they offer a wide range uses. Here are represented the standard versions without the respective valves which may be supplied on request.

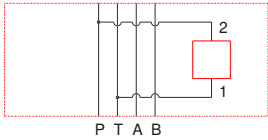
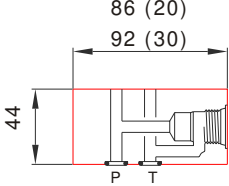
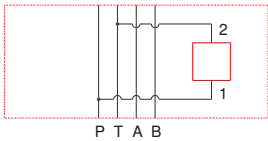
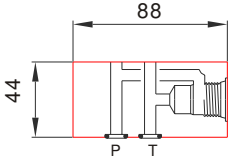
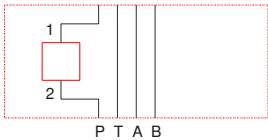
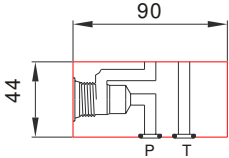
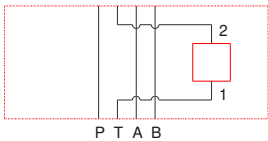
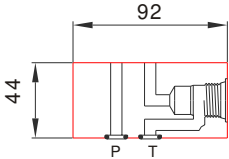
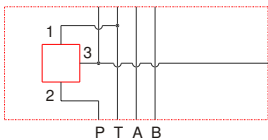
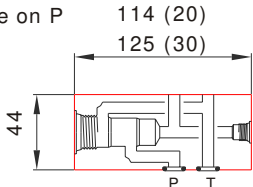
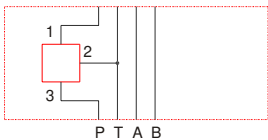
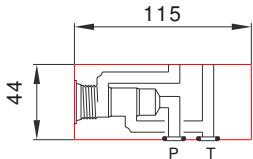
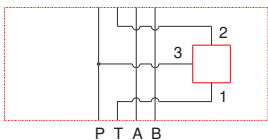
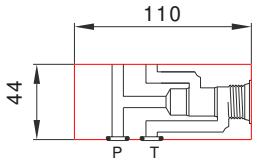
Connecting scheme	Type	Valve cavity	Technical schedules
Circuit 01 valve between P and T (2-1)  	20 CFT 01 30 CFT 01	S 20/2 S 30/2	13.010 13.010
Circuit 61 valve between P and T (1-2)  	30 CFT 61	S 30/2	13.020
Circuit 58 valve in pipe P  	30 CFT 58	S 30/2	13.030
Circuit 60 valve in pipe T  	30 CFT 60	S 30/2	13.040
Circuit 07 for pressure reducing valve on P  	20 CFT 07 30 CFT 07	S 20/3 S 30/3	13.050 13.050
Circuit 20 with priority on P and exceeding in T  	30 CFT 20	S 30/3	13.060
Circuit 24 overcenter on T  	30 CFT 24	S 30/3	13.070

A and B line regulation and interception.

It is a series of blocks for sandwich assembling on connection surface CETOP R35 H-4.2-4-03, available in several executions for two or three way valves in size 20 and 30, they offer a wide range of uses. Here are represented the standard version without the respective valves, which may be supplied separately. For complete groups' dimensions and features see technical schedules.

Connecting scheme	Type	Valve cavity	Technical schedules
Circuit 02 valves between A-B and T 	20 CFT 02 30 CFT 02	S 20/2 S 30/2	13.110 13.110
Circuit 03 valves between A and B 	30 CFT 03	S 30/2	13.120
Circuit 08 pressure reducing valve on A 	30 CFT 08	S 30/3	13.030
Circuit 09 pressure reducing valve on B 	30 CFT 09	S 30/3	13.140
Circuit 25 overcenter on A and B 	30 CFT 25	S 30/3	13.150
Circuit 33 valves on pipe A and B (1-2) 	30 CFT 33	S 30/2	13.160
Circuit 34 valves on pipe A and B (2-1) 	30 CFT 34	S 30/2	13.170

This series of bodies, realized in alluminium alloy and anodized includes all standard versions normally available.
 On request they can be supplied in galvanized or phosphated steel and with different uses.
 For out standard uses choiche please see technical schedule 17.010 (D - I - S type ports).

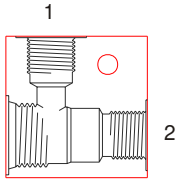
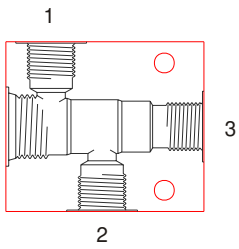
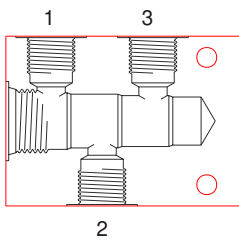
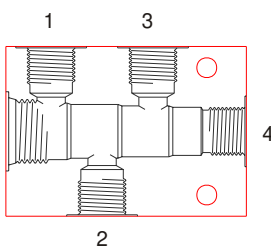
	Type	Valve cavity	Ports	Technical schedule
Body LO type - 2 way 	20-LO-B05	S 20/2	G 1/4 (B05)	16.010
	20-LO-B06	S 20/2	G 3/8 (B06)	16.010
	30-LO-B06	S 30/2	G 3/8 (B06)	16.010
	30-LO-B08	S 30/2	G 1/2 (B08)	16.010
	50-LO-B08	S 50/2	G 1/2 (B08)	16.010
	50-LO-B12	S 50/2	G 3/4 (B12)	16.010
	70-LO-B16	S 70/2	G 1 (B16)	16.010
	70-LO-B20	S 70/2	G 1.1/4 (B20)	16.010
Body C3 type - 3 way 	20-C3-B05	S 20/3	G 1/4 (B05)	16.010
	20-C3-B06	S 20/3	G 3/8 (B06)	16.010
	30-C3-B06	S 30/3	G 3/8 (B06)	16.010
	30-C3-B08	S 30/3	G 1/2 (B08)	16.010
	50-C3-B08	S 50/3	G 1/2 (B08)	16.010
	50-C3-B12	S 50/3	G 3/4 (B12)	16.010
	70-C3-B16	S 70/3	G 1 (B16)	16.010
	70-C3-B20	S 70/3	G 1.1/4 (B20)	16.010
Body CC type - 3 way 	30-CC-B05	S 30/4	G 1/4 (B05)	16.011
	30-CC-B06	S 30/4	G 3/8 (B06)	16.011
	30-CC-B08	S 30/4	G 1/2 (B08)	16.011
	50-CC-B08	S 50/4	G 1/2 (B08)	16.011
	50-CC-B12	S 50/4	G 3/4 (B12)	16.011
Body C4 type - 4 way 	20-C4-B05	S 20/4	G 1/4 (B05)	16.011
	20-C4-B06	S 20/4	G 3/8 (B06)	16.011
	30-C4-B06	S 30/4	G 3/8 (B06)	16.011
	30-C4-B08	S 30/4	G 1/2 (B08)	16.011
	50-C4-B08	S 50/4	G 1/2 (B08)	16.011
	50-C4-B12	S 50/4	G 3/4 (B12)	16.011

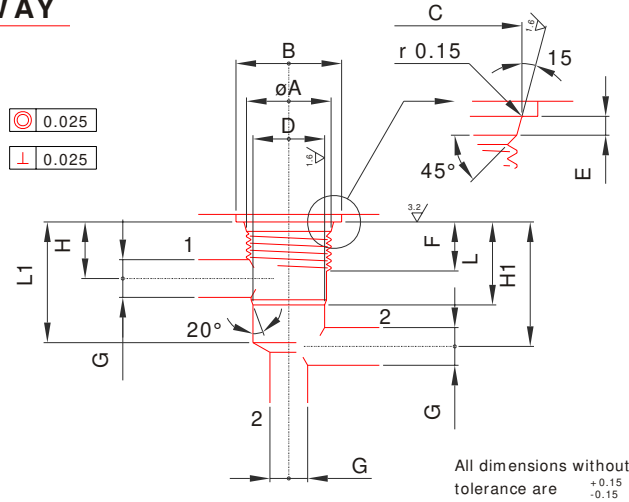
2 WAY

	S 20 / 2	S 30 / 2	S 50 / 2	S 70 / 2
A	M 18x1.5	M 22x1.5	M 33x2	M 42x2
B	23	28	40	50
C	19.8 ^{+0.10} ₋₀	23.8 ^{+0.10} ₋₀	35.4 ^{+0.10} ₋₀	44.4 ^{+0.10} ₋₀
D	15 ^{+0.027} ₋₀	19 ^{+0.033} ₋₀	28 ^{+0.033} ₋₀	38 ^{+0.039} ₋₀
E	2.6 ^{+0.20} _{-0.20}	2.6 ^{+0.20} _{-0.20}	3.1 ^{+0.40} ₋₀	3.3 ^{+0.20} ₋₀
F	11	13	16	19
G	8	10.5	15	20
H	13	15	21	26
H1	28	33	46	57
L	18.5	22	32	39
L1	27	32	42	52

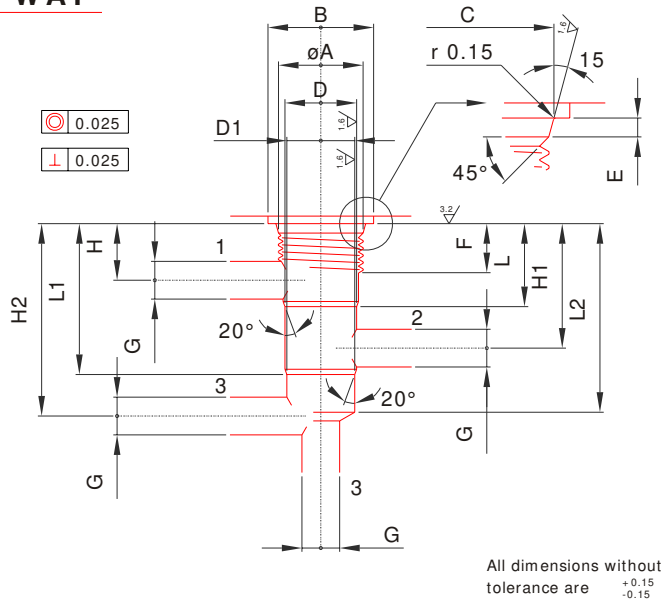
3 WAY

	S 20 / 3	S 30 / 3	S 50 / 3	S 70 / 3
A	M 18x1.5	M 22x1.5	M 33x2	M 42x2
B	23	28	40	50
C	19.8 ^{+0.10} ₋₀	23.8 ^{+0.10} ₋₀	35.4 ^{+0.10} ₋₀	44.4 ^{+0.10} ₋₀
D	15 ^{+0.027} ₋₀	19 ^{+0.033} ₋₀	28 ^{+0.033} ₋₀	38 ^{+0.039} ₋₀
D1	14 ^{+0.027} ₋₀	18 ^{+0.027} ₋₀	27 ^{+0.033} ₋₀	36 ^{+0.039} ₋₀
E	2.6 ^{+0.20} _{-0.20}	2.6 ^{+0.20} _{-0.20}	3.1 ^{+0.40} ₋₀	3.3 ^{+0.20} ₋₀
F	11	13	16	19
G	8	10.5	15	20
H	13	15	21	26
H1	28	33	46	57
H2	43	51	71	88
L	18.5	22	32	39
L1	33.5	40	56	70
L2	42	50	66	83

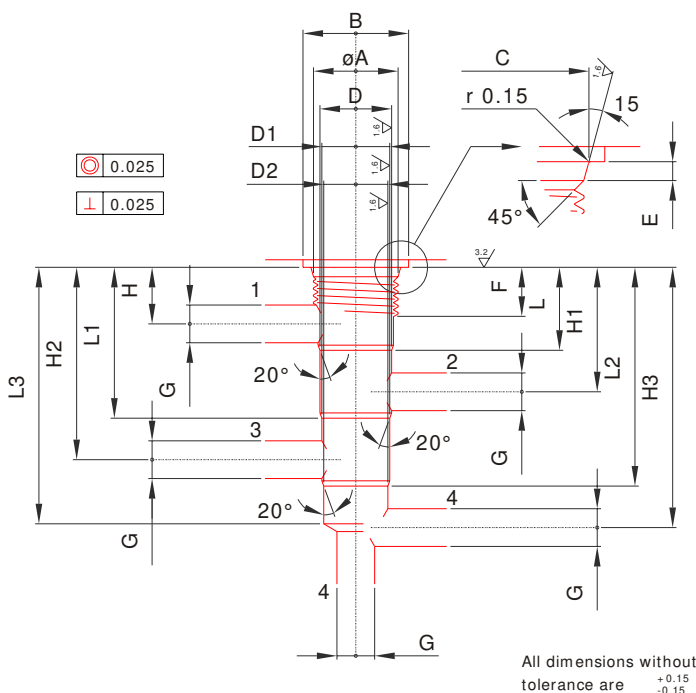
4 WAY

	S 20 / 4	S 30 / 4	S 50 / 4	S 70 / 4
A	M 18x1.5	M 22x1.5	M 33x2	M 42x2
B	23	28	40	50
C	19.8 ^{+0.10} ₋₀	23.8 ^{+0.10} ₋₀	35.4 ^{+0.10} ₋₀	44.4 ^{+0.10} ₋₀
D	15 ^{+0.027} ₋₀	19 ^{+0.033} ₋₀	28 ^{+0.033} ₋₀	38 ^{+0.039} ₋₀
D1	14 ^{+0.027} ₋₀	18 ^{+0.027} ₋₀	27 ^{+0.033} ₋₀	36 ^{+0.039} ₋₀
D2	13 ^{+0.027} ₋₀	17 ^{+0.027} ₋₀	26 ^{+0.033} ₋₀	34 ^{+0.039} ₋₀
E	2.6 ^{+0.20} _{-0.20}	2.6 ^{+0.20} _{-0.20}	3.1 ^{+0.40} ₋₀	3.3 ^{+0.20} ₋₀
F	11	13	16	19
G	8	10.5	15	20
H	13	15	21	26
H1	28	33	46	57
H2	43	51	71	88
H3	58	69	96	119
L	18.5	22	32	39
L1	33.5	40	56	70
L2	48.5	58	80	101
L3	57	68	90	114

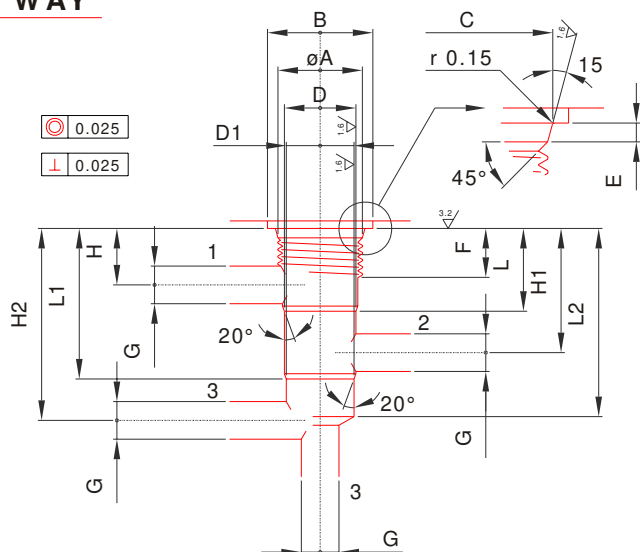
3 WAY

 All dimensions without tolerance are $\begin{matrix} +0.15 \\ -0.15 \end{matrix}$
S 28 / 3

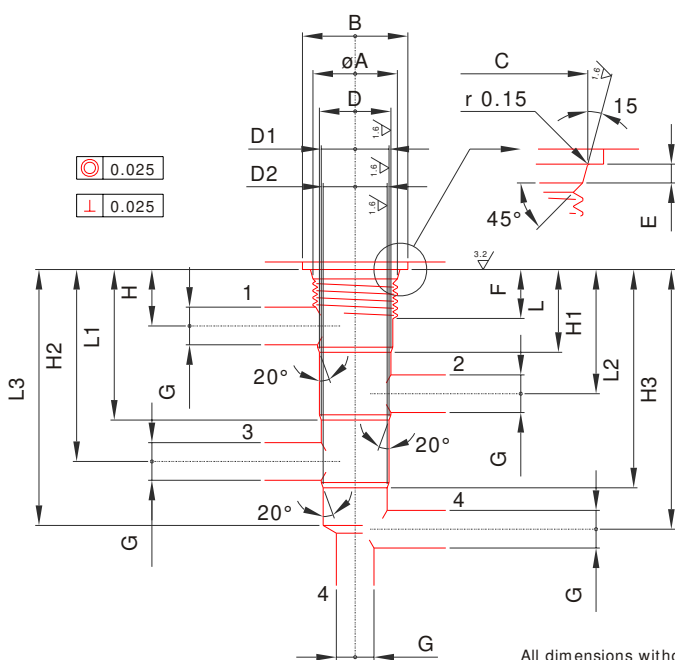
A	3/4-16 UNF
B	25
C	$20.6^{+0.10}_{-0}$
D	$15.87^{+0.05}_{-0}$
D1	$14.27^{+0.05}_{-0}$
E	$2.6^{+0.30}_{-0}$
F	12.5
G	6
H	15
H1	29
H2	44
L	20.5
L1	34.5
L2	50

4 WAY

 All dimensions without tolerance are $\begin{matrix} +0.15 \\ -0.15 \end{matrix}$
S 28 / 4

A	3/4-16 UNF
B	25
C	$20.6^{+0.10}_{-0}$
D	$15.87^{+0.05}_{-0}$
D1	$14.27^{+0.05}_{-0}$
D2	$12.70^{+0.05}_{-0}$
E	$2.6^{+0.30}_{-0}$
F	12.5
G	6
H	15
H1	29
H2	43
H3	58
L	20.5
L1	34.5
L2	49
L3	60

On standard bodies are normally provided with ports B (UNI 338-66).
Also bodies with ports D - I - S type can be supplied on request.

	Code	A	B	C	D	E	F	G	H	
B Type (UNI 338-66) 	B04	G 1/8	8	16.5	8.50	1.5	12	4	0.75	
	B05	G 1/4	12	21.2	11.50	1.5	16	6.5	1.00	
	B06	G 3/8	12	24.5	15.00	1.5	16	9.5	1.00	
	B08	G 1/2	14	29.2	18.75	2.0	19	13	1.25	
	B12	G 3/4	16	35.6	24.25	2.0	23	19	1.25	
	B16	G 1	18	43.5	30.50	3.0	26	25	1.50	
	B20	G 1.1/4	20	53	39.00	3.0	29	32	1.50	
D Type (UNI 4534-64) 	D04	M 12x1.5	12	21.2	10.25	1.5	16	4	1.00	
	D05	M 14x1.5	12	22.8	12.25	1.5	16	6.5	1.00	
	D06	M 18x1.5	12	26	16.25	2.0	16	9.5	1.00	
	D08	M 22x1.5	14	32.4	20.25	2.0	19	13	1.00	
	D12	M 26x1.5	16	35.6	24.25	2.0	23	19	1.00	
	D16	M 33x2	18	43.5	30.50	3.0	26	25	1.50	
	D20	M 42x2	20	53	39.50	3.0	29	32	1.50	
	Code	A	B	C	D	E	F	G	H	L
I Type (ISO 6149) 	I04	M 12x1.5	11.5	22	10.25	13.8	14	1.5	4	2.4
	I05	M 14x1.5	11.5	25	12.25	15.8	14	1.5	6.5	2.4
	I06	M 18x1.5	14.5	29	16.25	19.8	16.5	2	9.5	2.4
	I08	M 22x1.5	15.5	34	20.25	23.8	18	2	13	2.4
	I12	M 27x2	19	40	24.50	29.4	22	2	19	3.1
	I16	M 33x2	19	46	30.50	35.4	22	2.5	25	3.1
	I20	M 42x2	19.5	56	39.50	44.4	22.5	2.5	32	3.1
S Type (SAE-UNF-2B) 	S04	7/16-20	12	21	9.8	12.4	14	1.5	4	2.4
	S05	1/2-20	12	23	11.4	14	14	1.5	6.5	2.4
	S06	9/16-18	13	25	12.8	15.6	16	2	9.5	2.5
	S08	3/4-16	15	30	17.4	20.6	18	2	13	2.5
	S12	1.1/16-12	19	41	24.7	29.2	23	2	19	3.3
	S16	1.5/16-12	19	49	31	35.5	23	2.5	25	3.3
	S20	1.5/8-12	19	58	39	43.5	23	2.5	32	3.3

* (S04-S05-S06 = 12°)