

Operating and Installation Instructions

Filter control system

RM-208 CB.14.01 EasyLine

Supply voltage 24 V DC

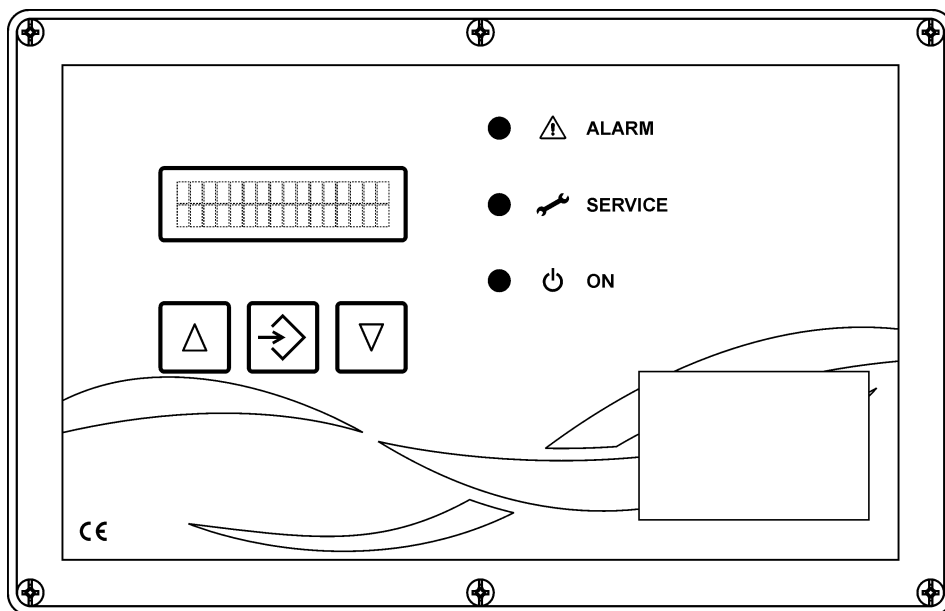

Table of Contents

1	Safety instructions.....	3
2	Equipment specification	3
3	Assembly.....	4
4	“Step by step” installation.....	5
5	“Step by step” settings	7
	5.1 Function when shipped.....	7
	5.2 Setting parameters	7
	5.3 Parameter list	9
6	Operating modes.....	10
	6.1 Test mode.....	10
	6.2 Down time cleaning	10
	6.3 Cleaning via start / stop input (external Δp switch).....	10
7	Troubleshooting	11
	7.1 Cleaning the controller	11
	7.2 Manufacturing.....	12
8	Text messages on the display.....	13
9	Details on the equipment function.....	14
10	Glossary.....	15
11	Technical specifications	16

Regulations

VDE 0160	EN 60.439 Part 500
EN 50178	2004/108 EC

Legends



Warning against physical and health hazards or damages to the product and other properties.



Attention, make absolutely sure to observe the notes in the documentation!



Important note



Identification of safety class II (protective insulation).
Complete double insulation or reinforced insulation.
The symbol is affixed to the device.



Identification of direct current (DC).

1 Safety instructions



The filter control system RM-208 CB when connected to the mains poses an electrical hazard. Device failure, serious or even fatal injuries may occur as a result of improper installation of the connected equipment. Consequently, follow in particular the points set out below in addition to the general safety regulations for equipment in industrial electrical installations:

- Installation of the device may be carried out only by qualified experts, in accordance with the provisions of IEC 364, DIN VDE 0105 for electrical equipment.
- All applicable laws, conditions, orders and regulations governing the setting up of electrical equipment must be observed with respect to the installation site.
- Setting of equipment with degree of protection IP00 without covers, may only be performed by authorized expert staff, when disconnected, and whilst observing the local safety and accident prevention regulations.
- The RM-208 CB may only be operated in the permitted operating area.
- Switch off the mains supply before replacing the filter control or any components connected to it. Otherwise the equipment may be damaged.

2 Equipment specification

The RM-208 CB is used to control 24 V DC solenoid valves on filtering separators with compressed air pulse cleaning. After connecting the supply voltage, the filter control system functions fully automatically without further activation.

3 Assembly

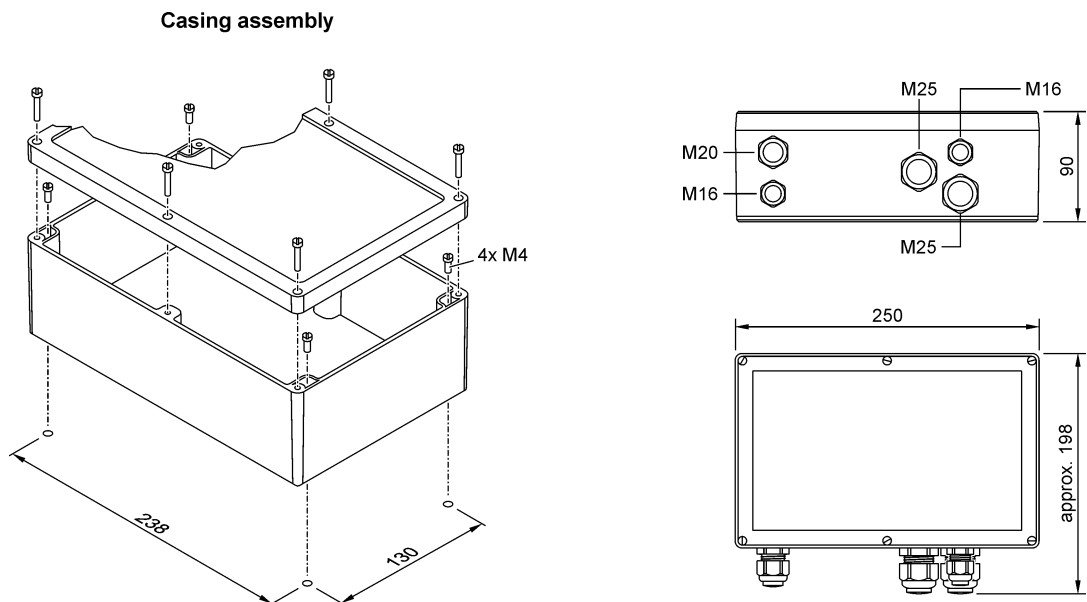

Wall-mounting of the filter controls is not permitted! The device may only be mounted to machine parts.

4 "Step by step" installation

1 Supply voltage connection

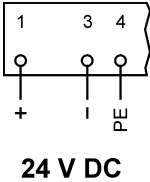

2 Solenoid valve connection

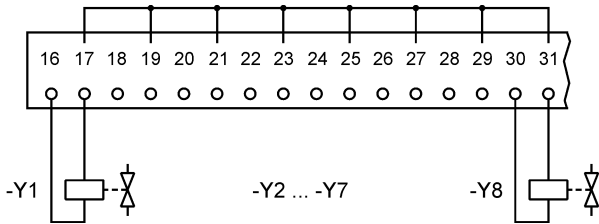

3 Connection of expansion modules RM-LV8 / RM-LV16

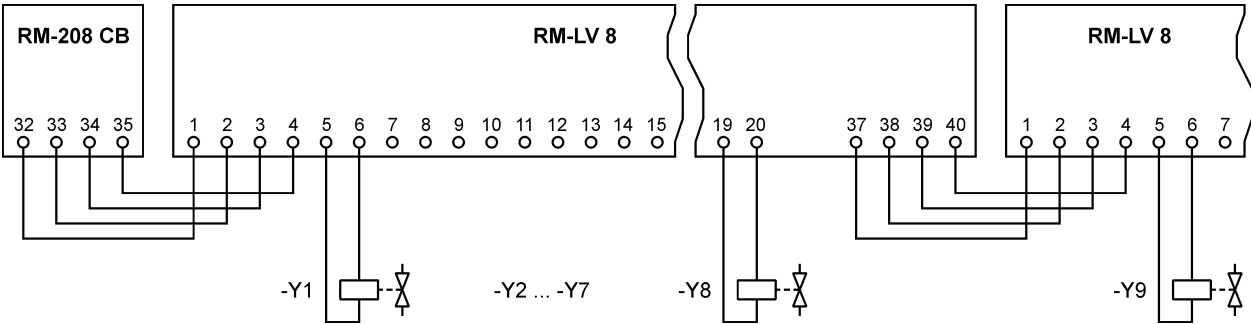

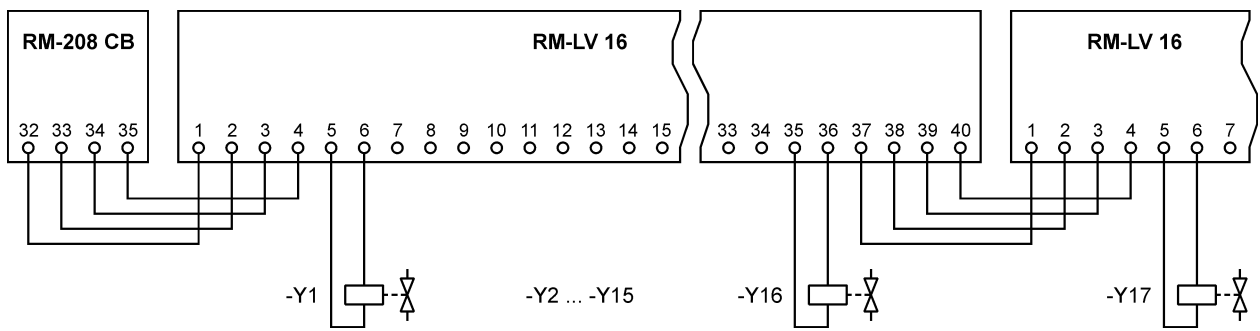

4 Other connections

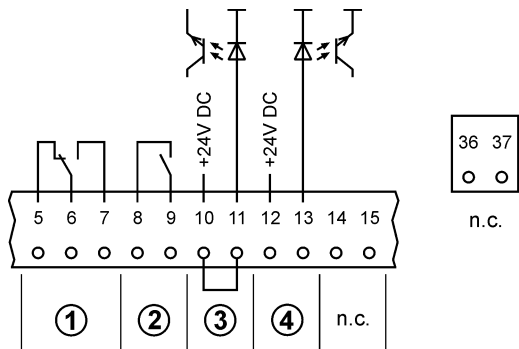

- ① "Common alarm" relay output
- ② Output to control an extractor element contactor
- ③ Down-time cleaning input (factory bridged)
- ④ Start/stop input (external Δp-switch)



- A device (switch, power circuit breaker) must be located in the proximity of the filter controller RM-208 CB, which enables the disconnection of all poles of the device from the mains voltage / supply voltage. The device (switch, power circuit breaker) has to be easy accessible for the user and to be marked as disconnecting device for the equipment.
- The wires and cables used for the connection of the controls must be suitable for an ambient temperature of up to 130 °C.
- Use shielded cable for all bus lines! The shielding must be connected unilaterally to the protective earthing (PE).
- Signal cables must not be laid parallel to power cables.
- Tighten all cable glands in use so the cables are properly enclosed and water cannot penetrate.
- Cable glands that are not in use must be closed or replaced by blind plugs.

5 “Step by step” settings

5.1 Function when shipped

The down time cleaning input 10, 11 is bridged at the factory. Once the supply voltage is at RM-208 CB, the solenoid valves are controlled consecutively in sequence. The filter control system automatically detects how many valves are connected.

For connecting an external Δp switch, see section 6.3 “Cleaning via start / stop input (external Δp switch)”.

To activate the down time cleaning, see section 6.2 “Down time cleaning”.

If another function is required or if additional functions are to be activated, the parameter setting of the RM-208 CB must be changed. See also section 5.2.

5.2 Setting parameters

To set or check the parameters, proceed as follows:

- 1 Use the parameter list in section 5.3 to search for the parameters you want to change or check. On the RM-208 CB, press buttons \blacktriangle and \blacktriangle simultaneously, for at least 3 seconds. The program then changes from operation mode to parameter selection mode. The parameter P01 “Pulse time” is displayed on the text display at its set value.
 - 2 Press the \blacktriangle button to call up all following parameters P02 ... P11 in sequence. The parameters already displayed can be accessed by repeatedly pressing the \blacktriangledown button.
 - 3 To change the value of a displayed parameter, press the ENTER button for at least one second. The program then changes from parameter selection mode to parameter setting mode.
 - 4 Press the \blacktriangle button to increase the parameter value displayed in increments. Press the \blacktriangledown button to decrease the parameter value displayed.
 - 5 Press the ENTER button for at least 3 seconds. The new parameter value is stored. The text display will briefly display the message “Store”. The program automatically returns to the parameter selection mode. You can now call up other parameters and check or change their values.
 - 6 So that the program changes from parameter selection mode to operation mode, press buttons \blacktriangle and \blacktriangle simultaneously for at least 3 seconds.
- If the program is still in parameter setting mode, follow the instructions given under point 5.

i

The symbols shown on the right will be shown in the lower left-hand corner of the text display. They indicate to the operator which mode the equipment is currently in.

+ - Operation mode
 +^ - Parameter selection mode
 +>- Parameter setting mode

If no buttons are pressed for 4 minutes, the RM-208 CB automatically returns from parameter selection mode or parameter setting mode to operation mode with the last values stored.

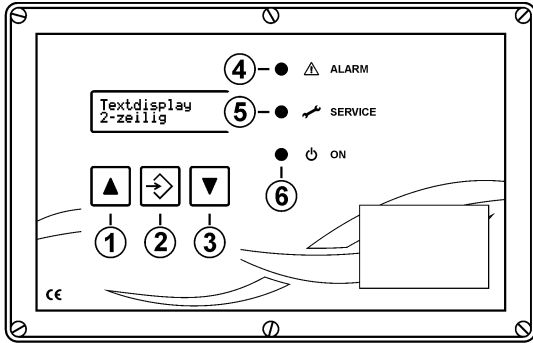

- ① ▲-button for selecting parameters or values (ascending)
- ② ENTER button for entering selected values
- ③ ▼-button for selecting parameters or values (descending)
- ④ LED "ALARM" is on when there is an alarm message (alarm relay pressed)
- ⑤ LED "SERVICE" is on when filter maintenance work is due
- ⑥ LED "ON" is on when the machine is in operation

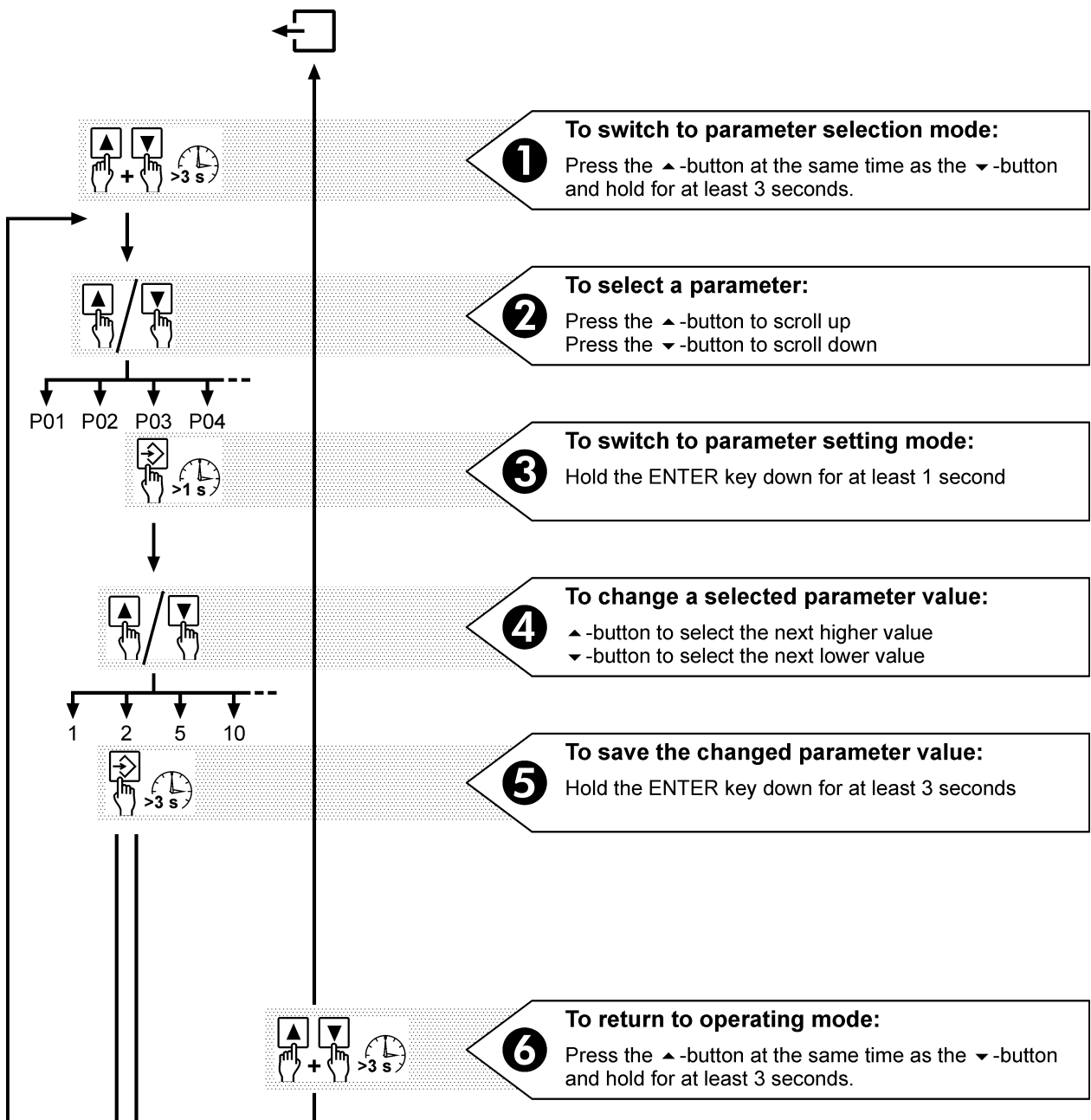

5.3 Parameter list

Param. no.	Text on the display	Explanation	Factory settings	Setting range
P01	P01 Pulse time	Pulse time	60 ms	15 ... 2500 ms
P02	P02 Interval	Pause time	10 s	1 ... 500 s
P03	P03 DT interval	Down time interval time	6 s	1 ...100 s
P04	P04 tot Valve no	Total no. of valves*	0	0 ... 128
P05	P05 DT cycles	Down time cleaning cycles	6	0, 2 ... 32
P06	P06 Operating h	Operating hours	–	0 ... 250000 h
P07	P07 Language	Language for the display text	D	D, GB, F, I, NL, DK, FIN, PL, E
P08	P08 Test Mode	0 = Test mode off 1 = Valve test 2 = Input test 3-5 = For manufacturer purposes only	Off (0)	0 ... 5
P09	P09 Ser.run hour	Service operating hours	–	–
P10	P10 Ser.run h.AL	Service operating hours alarm	0 h**	0 ... 25000 h**
P11	P11 Ser.r.h.Code	Service operating hours code	0	0 ... 250

* Number of all valves connected to the RM-208 CB and to the expansion modules. The parameter is used by the equipment for internal monitoring purposes and need only be set, if expansion modules are fitted. If the equipment detects that the total number of valves set is different from the actual number of valves controlled, an alarm message is issued.

** If the parameter is set to the value 0 h, the alarm is switched off.

i The parameters P09 and P10 are only displayed if the service operating hours code (parameter P11) has been entered.

6 Operating modes

6.1 Test mode

In test mode, the most important functions in the control sequence are checked and shown on the text display. To start test mode, call up parameter no. P08 "Test mode" (see section 5.2 for more information) and select one of the following test modes:

Test mode 1 (Valve test)

Each valve connected is activated in sequence and shown in the text display.

Test mode 2 (Input test)

The signal statuses of the inputs are displayed on the text display.

Test modes 3-5

For manufacturer purposes only

Test mode 0 (test mode off)

Test mode is switched off.

6.2 Down time cleaning

To activate down time cleaning, perform the following steps:

- Remove the factory-fitted wire jumper on input 10, 11.
- Connect a free auxiliary contact (make contact) of the fan contactor to terminals 10 and 11. The input should be operated in isolation.
- Set parameter P05 "Down time cleaning cycles" to the required number of cycles (see also section 5.2 "Setting parameters").

If the fan is switched on, the contact on 10, 11 closes and switches on the cleaning. When switching off the fan, the contact on 10, 11 opens and activates the down time cleaning. The down time cleaning cycles set are carried out. The RM-208 CB then shuts down.

6.3 Cleaning via start / stop input (external Δp switch)

If the cleaning is controlled via an external Δp switch, the isolated contact on the Δp switch must be connected to the start / stop input 12, 13.



During down-time cleaning, the start / stop input 12, 13 is inactive.

7 Troubleshooting

Error	Possible causes	Recommended action
The "ON" LED is not lit and input 10, 11 is bridged.	- No mains voltage	- Check power feed
	- Device fuse is defective	- Replace fuse
	- EMERGENCY STOP activated	- Check EMERGENCY STOP
No valve activity	- No control system release	- Bridge input 10, 11
	- Wiring to valves interrupted	- Check cables and electrical connections
	- Magnet coil faulty	- Replace coil
No down time cleaning	- Parameter P05 = 0 (down time cleaning cycles)	- Set parameter P05 "Down time cleaning cycles" to a different value
	- There is no signal from the fan control	- Activate signal to input 10, 11
Cleaning ineffective	- Interval time too long	- Set parameter P02 "Interval" to a lower value
	- Pressure too low	- Set pressure to 6 ... 8 bar (min. 5 bar) - Set parameter P02 "Interval" to a higher value
	- Valve faulty	- Check / replace valves
	- Pulse time too short	- Set parameter P01 "Pulse time" to a higher value
"Alarm" LED on	- The number of valves is set incorrectly	- Set parameter P04 "Total no. of valves" correctly

7.1 Cleaning the controller

Wipe only with a damp cloth if outside of device is soiled.

7.2 Manufacturing

The filter control system RM-208 CB was manufactured by:

RECO Gesellschaft für Industriefilterregelung mbH
Junkersring 11
D-53844 Troisdorf
Germany
+49 (0) 2241 39704-0

for:

Norbert Heinrich Automatisierungstechnik
Feldstraße 16
32549 Bad Oeynhausen
Germany
Tel.: +49 (0) 5734 6002318



Please contact Norbert Heinrich Automatisierungstechnik to obtain technical support.

8 Text messages on the display

Display	Explanation
Reset RM204VXX	Reset status and text version The text message is displayed for approx. 1 second after the voltage is switched on.
Stand By + - Val.No	Controller is not enabled through inputs 10 and 11.
Cleaning Off + - Val.No	The control has been enabled via input 10, 11 and stopped via input 12, 13.
Cleaning On + - Val.No	The control has been enabled via input 10, 11 and started via input 12, 13.
DTC Cleaning ON + - 000 Pcs	Down time cleaning active
Call Service + - Val.No	The alarm switching point for the service hours counter has been exceeded.
RM-LVX Alarm + - Val.No	A connected I/O module RM-LV8 or RM-LV16 is out of order or the total number of valves (parameter P04) is set incorrectly. or the valve outputs of a connected I/O module RM-LV8 or RM-LV16 are not taken in sequence.

9 Details on the equipment function

Cleaning

Cleaning starts at the first valve. If the cleaning is interrupted via the start/stop input 12, 13, the control sequence is continued at the next cleaning procedure. The cleaning then starts at the valve following the last valve activated.

If the control is reactivated following a mains voltage failure, a restart is carried out.

Relay output 8, 9 to control extractor elements

If automatic components for dust removal (extractor elements) are fitted, these need to be in operation during cleaning and during down time cleaning. Connect the cut-out for controlling these drive units to the isolated output 8, 9.

“Alarm” relay output 5, 6, 7

As soon as the supply voltage is present on the RM-208 CB, relay contact 5, 6 closes and contact 6, 7 opens. In the following situations, relay contact 5, 6 opens and contact 6, 7 closes:

- Supply voltage failure
- Failure of a voltage internal to the equipment
- Fault in a connected O module
- Total number of valves is set incorrectly (parameter P04)

10 Glossary

Term	Explanation
Cleaning	Cleaning the filter elements using compressed air pulses.
Compressed air pulse cleaning	Cleaning of the filter elements using compressed air pulses.
Differential pressure	Difference between the air pressures Δp on the pure gas side (behind the filter element) and the crude gas side (in front of the filter element) of the filter.
Down time cleaning	Cleaning the filter elements after the system is shut down for a set duration or number of cycles.
Down time cleaning cycles	The number of cleaning cycles performed in the down time cleaning.
Down time cleaning input	Input on the RM-208 CB for starting the down time cleaning.
Down time interval time	Pause time during the down time cleaning.
Expansion module	If the filter has more than 8 valves, expansion modules of type RM-LV8 (for 8 valves) or RM-LV16 (for 16 valves) are required. A maximum of 7 type RM-LV16 expansion modules can be connected to the main RM-208 CB equipment. With the outputs on the main equipment, this makes a maximum of 120 valve outputs available.
Extractor element	Device for extracting the filter casing from the dust deposited. E.g. cellular wheel sluice, trough conveyor worm.
Extractor element contactor	Contactors which switch an extractor element drive unit on and off.
I / O module	Input / output module (module for the input and output of control signals)
Operation mode	Status of the RM-208 CB in which the equipment is ready for operation.
Parameter selection mode	Status of the RM-208 CB in which the equipment operator can select a parameter.
Parameter setting mode	Status of the RM-208 CB in which the equipment operator can set a parameter.
Pause time (also Interval time)	Time period between two consecutive control pulses from the valve outputs when the cleaning is running.
Pulse time	Duration of a control pulse on the valve outputs
Service operating hours alarm	Alarm issued when the operating hours set for the maintenance interval has elapsed.
Service operating hours code	Code which needs to be entered to change the set value for the service operating hours.
Solenoid valve	(also relay valve) electromagnetically operated valve for the pneumatic triggering of the filter membrane valves. The membrane valves in turn release the compressed air strokes for filter cleaning.
Start / stop input	Input on the RM-208 CB for starting and stopping the cleaning via an external Δp switch.
Total no. of valves	Number of all valves connected to the RM-208 CB and to the expansion modules.
-Y1, -Y2, -Y3, ...	Designations of solenoid valves 1, 2, 3, ...
Δp switch	Switch which is triggered by a differential pressure value set and which activates the filter cleaning.

11 Technical specifications

Application	Data																
Supply voltages	24 V DC Power consumption: max. 30 W Back-up fuse: max. 4 A  The power must be supplied via an UL class 2 power supply!																
Signal inputs	24 V DC, operate ensuring isolation																
Signal output	Relay outputs, max. 2 A, 250 V or 1 A, 30 V DC																
Control outputs for valves	For valves with a rated voltage of 24 V DC, can be expanded to 120 outputs, Output power in pulse mode 42 Watt																
Outputs for expansion modules	Supply voltage and pulse wires to the expansion modules																
Temperature range	-20°C to +50°C																
Protection class	Housing IP-66 not evaluated by UL / Type 5 Installation torque of cover screws: 1,5 Nm																
Weight	approx. 0.8 kg																
Installation height	max. 2000 m above M.S.L.																
Electrical connections	Tension spring terminals Permissible wire gauge single-wire: 22 ... 16 AWG / 0.5 ... 1.5 mm ² Flexible: 22 ... 16 AWG / 0.5 ... 1.5 mm ²																
Cable glands	<table border="1"> <thead> <tr> <th>Size</th> <th>Sealing range</th> <th>Cord diameter range</th> <th>Installation torque</th> </tr> </thead> <tbody> <tr> <td>M16x1.5</td> <td>5 ... 10 mm</td> <td>5.6 ... 10 mm</td> <td>2.0 Nm</td> </tr> <tr> <td>M20x1.5</td> <td>8 ... 13 mm</td> <td>9 ... 13 mm</td> <td>2.7 Nm</td> </tr> <tr> <td>M25x1.5</td> <td>11 ... 17 mm</td> <td>13 ... 17 mm</td> <td>5.0 Nm</td> </tr> </tbody> </table>	Size	Sealing range	Cord diameter range	Installation torque	M16x1.5	5 ... 10 mm	5.6 ... 10 mm	2.0 Nm	M20x1.5	8 ... 13 mm	9 ... 13 mm	2.7 Nm	M25x1.5	11 ... 17 mm	13 ... 17 mm	5.0 Nm
Size	Sealing range	Cord diameter range	Installation torque														
M16x1.5	5 ... 10 mm	5.6 ... 10 mm	2.0 Nm														
M20x1.5	8 ... 13 mm	9 ... 13 mm	2.7 Nm														
M25x1.5	11 ... 17 mm	13 ... 17 mm	5.0 Nm														

Disclaimer

The contents of this documentation has been verified for correctness and completeness. Nevertheless, errors can not be excluded so that we cannot guarantee the correctness of this information. Subject to alterations at any time.