

Disk type non-return valves RV Solid series

Type: P740, P741, P745, P750 and P760

Size:

DN 010 – 150, OD 0.50" – 6.00", ISO 008 – 125

- Copy of the original operating manual -

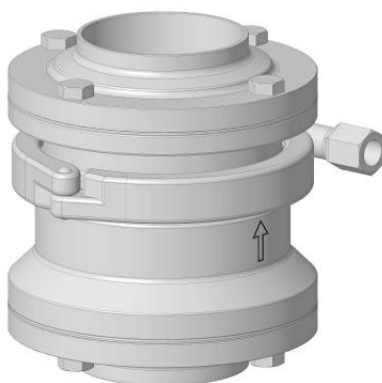

Version 1.03



en

1 / 34

Copy of the original operating instructions

BAA RV Solid

1. Contents

1. Contents.....	2
2. Safety instructions	4
2.1. Warnings	4
2.2. General.....	4
2.3. Maintenance and service work	5
2.4. Modifications of the disk type non-return valve.....	5
2.5. Operation, handling	6
2.6. Spare parts	6
2.7. Risk assessment	6
3. Intended use	7
3.1. scope of application	7
3.2. Use, structure and method of working	7
3.3. Storage	7
3.4. Service Life	7
3.5. ATEX Use	7
3.6. Setting of the usage, user groups.....	8
3.7. Area of use of disk type non-return valves	8
3.8. Permissible operating media, pressures and temperatures	8
3.8.1. Limiting devices.....	9
3.8.2. Instructions for all disk type non-return valves	9
3.8.3. Hygiene instructions for all disk type non-return valves in the foodstuffs industry.....	9
3.9. Place of use, environment	10
3.10. Spatial and procedural limits	10
4. Materials and surfaces	11
4.1. Materials in the product area	11
4.2. Surfaces.....	11
5. Welding and mounting instructions.....	12
5.1. General instructions.....	12
5.2. Delivery condition of the disk type non-return valve	12
5.3. Installation guidelines	12
5.3.1. Installation space	12
5.3.2. Installation	12
5.4. Welding guidelines.....	12
5.5. Weld seam preparation	12
5.6. Welding	13
5.7. Welding filler	13
5.8. Weld seam finishing.....	13
5.8.1. Interior	13



5.8.2.	Exterior	13
5.9.	Cleaning of the valve.....	13
5.10.	Valve assembly.....	13
6.	Commissioning of disk type non-return valve	14
7.	Maintenance of disk type non-return valves	15
7.1.	Inspection of the disk type non-return valve.....	15
7.2.	Maintenance, troubleshooting and repair of the disk type non-return valve.....	15
7.2.1.	Seal gaskets.....	15
8.	Cleaning, disinfection	16
9.	Operating equipment and auxiliary media	16
9.1.	External cleaner (foam, gel or spray cleaner for external cleaning of disk type non-return valves).....	16
10.	Decommissioning	17
11.	Disposal	17
12.	Technical data	18
12.1.	Dimensions	18
12.2.	Weights.....	19
12.3.	Valve use.....	20
13.	Valve connection piping	20
13.1.	Installation position	20
13.2.	Valve connections.....	20
13.3.	Installation details for disk type non-return valves	20
14.	Disassembly – Assembly	21
14.1.	Preparatory measures for disassembly – assembly.....	21
14.2.	Spare parts.....	22
14.3.	Assembly tools.....	22
14.4.	Assembly of joint clamp.....	22
14.5.	Assembling the O-rings.....	23
14.5.1.	Dismantling the O-rings.....	23
14.5.2.	Installing the O-rings.....	23
14.6.	Replacement of the seals in contact with the product.....	23
14.6.1.	Disk type non-return valve, type P740, P741, P745 and P760	23
14.6.2.	Disk type non-return valve, type P750	25
15.	Malfunctions – troubleshooting.....	26
16.	Replacement parts lists	27
16.1.	Disk type non-return valve, type P740, P741, P745 and P760.....	27
16.2.	Disk type non-return valve, type P750	29
17.	Service address	34

2. Safety instructions

2.1. Warnings



DANGER



Death, severe injury or significant damage **will occur** if the corresponding precautionary measures are not taken.



WARNING



Death, severe injury or significant damage may occur if the corresponding precautionary measures are not taken.



CAUTION



Slight injury may occur if the corresponding precautionary measures are not taken.

Information/notice



You can get information and notes to effectively and safely carry out the following activities here.

2.2. General

Information/notice



Each person involved with the assembly, commissioning, operation and maintenance of this disk type non-return valve must have read and understood the complete operating instructions consisting of the below mentioned documents.

- ⇒ Operating Instructions for disk type non-return valves, RV Solid series
- ⇒ EC Declaration of Conformity

- ⇒ Disk type non-return valves by Pentair SÜDMO GmbH have been built using state-of-the-art standards and recognized safety regulations. However, these disk type non-return valves may constitute a hazard if used improperly by operating personnel or for a purpose other than the intended one. This can result in danger to the life and limb of the user or third parties, or damage the functionality of the disk type non-return valve and other material assets.
- ⇒ The following points ensure the proper use of the disk type non-return valve:
 - the observance of all safety instructions in the operating instructions for the disk type non-return valve.
 - the observance of all applicable national and international laws, ordinances, regulations, directives and other rules at the installation location.
 - In-house operation and safety regulations.
 - The carrying out of regular inspection and maintenance work.

Information/notice



Pentair Südmö GmbH shall not be liable for damage arising from the improper use of the disk type non-return valve.

- ⇒ The exact specification of the disk type non-return valve, such as
 - order number of the valve
 - seal sets
 - operating pressure
 - control air pressure
 - etc.

can be found on the label attached to the valve body.

2.3. Maintenance and service work

- ⇒ Any maintenance and service work on the disk type non-return valves must only be carried out by trained and qualified personnel.
 - Training or instruction according to the current standards of the safety regulations.
 - For systems with explosion protection: Training or instruction or authorization to carry out work on the systems subject to explosion hazards (observe ATEX regulations).
- ⇒ Get information on possible risks that could be caused by residues of the operating material and take appropriate measures if necessary (safety gloves, safety goggles etc.), before carrying out maintenance and service work on the disk type non-return valve.
- ⇒ Prior to carrying out any maintenance and service work, make sure that
 - the work is only carried out in a depressurized state and with the media supply shut off.
 - Before starting with a disassembly, the disk type non-return valve must be rinsed with cold water for a sufficient period in order to ensure that no cleaning products or hot water can be found. (Afterwards the disk type non-return valve must be emptied).
 - the disk type non-return valve and all piping elements leading to the valve have been drained, cleaned or flushed.
 - the fittings have cooled down.
 - the commissioning of the system by a third party is ruled out.
 - The pressure build-up which may form in pipelines is counteracted.
 - disassembly - assembly of the disk type non-return valve is carried out according to the assembly instructions (see chapter "Disassembly - Assembly" of the relevant assembly instructions).
 - the disk type non-return valve is removed from the pipeline section, if possible.
- ⇒ Avoid any working method that impairs the safety and function of the disk type non-return valve.

2.4. Modifications of the disk type non-return valve



DANGER



- ⇒ Operate the disk type non-return valve in accordance with regulations and having due regard for safety and an awareness for hazards.
- ⇒ Only operate the disk type non-return valve in a perfect technical condition.
- ⇒ Modifications of the disk type non-return valve are strictly forbidden.

2.5. Operation, handling



DANGER



- ⇒ Never touch the valve or pipelines if hot media are being processed or if the sterilization process is running.
- ⇒ Operating parameters (see "Permissible operating media, pressures and temperatures") must always be strictly observed.

- ⇒ The disk type non-return valves are to be operated exclusively by competent and trained operating personnel.
- ⇒ The operator of the disk type non-return valves must draw up operating instructions so that all the information required for the operation of the fittings is available to the operating personnel.
- ⇒ The operator of the disk type non-return valves must ensure that the described required safety and limiting systems in the environment of the fittings are continually functional and that they cannot be switched off during operation or changed with respect to their intended use.
- ⇒ Do not touch or otherwise manipulate the disk type non-return valves during operation or while operating the system in which these valves are installed.
- ⇒ The operating personnel must be instructed by the disk type non-return valve operator to wear protective clothing (gloves and safety goggles) during cleaning, flushing and sterilization work.

2.6. Spare parts

Information/notice



- Only use original spare parts.
- ⇒ Original spare parts, see spare parts of the respective disk type non-return valve.
- ⇒ Smooth operation of the disk type non-return valve is only guaranteed when using original spare parts.

2.7. Risk assessment

- ⇒ All safety instructions in this operating manual are the result of risk assessment for the disk type non-return valve.

3. Intended use

3.1. scope of application

⇒ These operating instructions are only valid for the following valves:

Disk type non-return valves

Type P740 / P741 / P745 / P750 / P760

Sizes DN 010 – 150
OD 0.50" – 6.00"
ISO 008 – 125

3.2. Use, structure and method of working

- ⇒ The plate check valves are suitable for preventing the back flow of liquid media against the desired flow direction if the feed pressure drops – e. g. if a pump fails.
- ⇒ The plate check valves are characterized by the fact that a flow path can be closed in one direction by a closing body fitted with an elastomer seal, but can be opened in the other direction by the pressure of a flowing liquid.
- ⇒ In the closed position, the closing body is pressed into a seal seat by the superposition of a spring force with a pressure force in the same direction.
- ⇒ For energy-saving reasons, the spring force is kept very low, so that full, tight closing does not always occur in the absence of a pressure force in the same direction.
- ⇒ A plate check valve is not suitable for use as a permanent shut-off valve when there is no feed pressure.
- ⇒ If there is pressure in the flow direction that can overcome the restoring forces described above, the closing body is removed from the seal seat and the flow is enabled.
- ⇒ Each plate check valve has a valve seat and a closing body.
The valve seats are axially sealed.
- ⇒ A recommended use of plate check valves is to install them in pipeline systems downstream of pumps. Installed in this position, the valves prevent media from flowing back from a plant area with a higher pressure level (e.g. a pressure tank) to a plant area with a lower pressure level (e.g. a supply tank) in the event of a pump malfunction.

3.3. Storage

- ⇒ Store the valve in a dry place protected against external influences.
- ⇒ Do not expose to direct sunlight
- ⇒ Prior to handling (disassembly of the valve body), temporarily store the valves in a dry place at an ambient temperature of $\geq 5^{\circ}\text{C}$ for at least 24 hours.

3.4. Service Life

The foreseeable service life of disk type non-return valves is 15 years.

3.5. ATEX Use

- ⇒ The disk type non-return valves comply with the requirements of Directive 2014/34/EU of the European Parliament and the Council and are suitable for use in potentially explosive atmospheres.
- ⇒ The valves must not be operated outdoors, if its service location there is classified as area with risk of explosion pursuant to Directive 2014/34/EU of the European Parliament and of the Council.



Operating Instructions

Disk type non-return valves

RV Solid series

Type: P740, P741, P745, P750 and P760

DN 010 – 150, OD 0.50” – 6.00”, ISO 008 – 125

- ⇒ Usage of the disk type non-return valves "underground" is not permitted.
- ⇒ The service rooms must be free of dust.
Dust deposits on the fittings must be avoided.
- ⇒ The system in which the disk type non-return valves are installed must be grounded.
- ⇒ The ignition temperatures of existing potentially explosive media must not be exceeded by hot media within the fittings or the hot surface temperatures of the fittings.
- ⇒ The disk type non-return valves have a corresponding fitting identification, which corresponds to Directive 2014/34/EU of the European Parliament and the Council as well as the standard DIN EN 80079-36:2016-12.
- ⇒ The specifications on the respective type plate apply to each disk type non-return valve.

	UK CA	II 2 G Ex h IIB 80°C...150°C Gb
		II 2 D Ex h IIIC T150°C Db

3.6. Setting of the usage, user groups

- ⇒ The fittings are only intended for commercial use.
Private use of the fittings is not permitted.
- ⇒ The fittings may only be unpacked, transported, mounted, assembled, connected, commissioned, operated, serviced, repaired, dismantled, decommissioned, stored and disposed of by qualified personnel.
- ⇒ Heavy valves must be transported with suitable load handling equipment in accordance with the valid national, regional and internal company regulations.

3.7. Area of use of disk type non-return valves

- Use of Pentair Südmö disk type non-return valves, for example in
- ⇒ breweries
 - ⇒ the beverage industry
 - ⇒ the foodstuffs industry
 - ⇒ the pharmaceutical industry
 - ⇒ the chemical industry
 - ⇒ the cosmetic industry

3.8. Permissible operating media, pressures and temperatures

Sealant	Media	Maximum permissible operating pressure PS						Maximum permissible operating temperature TS Maximum permissible media concentration C (dilution of the concentrate)																
		Fluid media and non-condensable gases		Water vapor in continuous operation		Water vapor in short-term operation (max. 20 min/day)		Fluid product media ¹		Non-condensable gases		Water vapor in continuous operation		Water vapor in short-term operation (max. 20 min/day)		Aqueous cleaning base (based on sodium hydroxide)			Aqueous cleaning acid (based on nitric acid)			Aqueous disinfectants (based on peracetic acid)		
		PS	PS	PS	PS	PS	PS	TS	TS	TS	TS	TS	TS	C	TS	C	TS	C	TS	C	TS			
Unit	bar over pressure	psig	bar over pressure	psig	bar over pressure	psig	°C	°F	°C	°F	°C	°F	°C	°F	%	°C	°F	%	°C	°F	%	°C	°F	
EPDM	Types P740, P741,	10,0	145	1,7	25	3,7	54	95,0	203	95,0	203	130,0	266	150,0	302	5,0	80,0	176	3,0	40,0	104	0,7	30,0	86
FKM ²	P745, P750, P760	10,0	145	NA	NA	1,0	15	80,0	176	80,0	176	NA	NA	121,1	250	5,0	80,0	176	1,5	60,0	140	0,2	30,0	86

¹ The maximum permissible temperature should be at least 1 K below the evaporation temperature of the media at atmospheric pressure!

² The temperature values presented for the sealing material FKM are assumptions that can be classified as "probably suitable".



3.8.1. Limiting devices

In order to prevent the operating thresholds, such as pressures and temperatures, described in "Permissible operating media, pressures and temperatures" either being exceeded or not reached, the system, in which the disk type non-return valves are integrated, must be equipped with the following limiting devices:

⇒ Control devices:

Suitable, manually or automatically operable control devices to maintain the operating parameters within the permissible threshold values.



⇒ Monitoring devices:

Suitable monitoring devices, which enable appropriate manual or automatic intervention, trigger corrective measures and/or shutting down or locking, in order to maintain the operating parameters within the permissible threshold values.

⇒ Safety devices:

Suitable safety devices such as safety valves or burst disk safeguards, which ensure, as the last hazard prevention measure, that the permissible operating pressures described in "Permissible operating media, pressures and temperatures" are not exceeded.

3.8.2. Instructions for all disk type non-return valves

 DANGER	
	<p>If liquids, emulsions or fluids in the valve are above their evaporation temperature at atmospheric pressure, sudden evaporation of the entire contents of the pipeline into the operating chamber and consequently a risk of injury for persons in the operating room may occur when the valve is switched on or when leakage occurs due to seal wear.</p> <p>The disk type non-return valve operator must ensure that hot media do not exceed the ignition temperature in the pipeline system.</p>

Information/notice	
	<p>When using ready-made cleaning agents or other aggressive media, make sure that these are suitable for the stainless steel and sealing material used and that they do not cause any damages to these materials.</p> <p>In case of doubt, please consult the valve manufacturer.</p>

3.8.3. Hygiene instructions for all disk type non-return valves in the foodstuffs industry

The operator of the disk type non-return valves must ensure that the valves are used exclusively in accordance with their intended use.

This particularly applies to the exclusive use of admissible media, to the exclusion of inadmissible media and compliance with the permissible concentrations and temperatures of cleaning agents and disinfectants.

It also applies in particular to compliance with the measures as described in a maintenance plan, which ensure that the required hygiene status of the fittings is maintained within fixed intervals. These measures include regular cleaning-in-place (short: "CIP") of the valve interior. In some cases, this includes regular "Sanitization-in-place" disinfection (short: "SIP") of the valve interior.



DANGER



Hazards resulting from pollution or contamination caused by the use of

- ⇒ non-permissible media in the valves or
- ⇒ due to improper cleaning or
- ⇒ improper disinfection

of the valves and which can lead to an adverse effect on the processed foods in the valves.

Examples:

- ⇒ Substances which result from corrosion
- ⇒ Residues of cleaning media
- ⇒ Residues of disinfection media

Failure to comply with the hygiene instructions

Risk of accidents ⇒ severe injuries may occur

3.9. Place of use, environment

- ⇒ The disk type non-return valves are mainly used in breweries, as well as the food and beverage, and pharmaceutical, chemical and cosmetic industries.
- ⇒ They are used in service room locations with floors resistant to acids and alkalis.
- ⇒ The locations must be equipped with normal room lighting so that the labels and warning signs on the valves are clearly visible at all times.
- ⇒ Permissible ambient temperature: -10 °C – +55 °C
- ⇒ Air humidity: 100% relative up to a temperature of 25 °C.
- ⇒ Wet area.

3.10. Spatial and procedural limits

- ⇒ The disk type non-return valve described here generally extends in terms of space up to the pipe connections, as illustrated in the following dimensional drawings.
Welded process connectors that are not explicitly illustrated are not included for calculating the spatial contents of the fittings.
- ⇒ Spatial and process engineering limits of the disk type non-return valves are diagrammatically presented in the chapter "Technical Data".

3.11. Operating media and operating limits

- ⇒ Permissible minimum temperatures for operating media:
 - Disk type non-return valve with the sealing material EPDM
 - ≥ -10.0 °C for gases
 - ≥ -10.0 °C for fluid media with freezing point ≤ -10 °C
 - > 1.0 K above freezing point for fluid media with freezing point > -10 °C
 - Disk type non-return valve with the sealing material FKM
 - ≥ +1.0 °C for gases
 - ≥ +1.0 °C for fluid media with freezing point ≤ 0 °C
 - > 1.0 K above freezing point for fluid media with freezing point > 0 °C
- ⇒ Maximum permissible operating pressures in connection with permissible operating media, maximum permissible operating temperatures and the applicable sealing materials at the "Product connections" process engineering interfaces are shown in the chapter "Permissible operating media, pressures and temperatures".

- ⇒ Media suitable in principle:
 - Liquids, e.g., water, beverages, etc.
 - Non-condensable gases, e.g., air, oxygen, nitrogen, etc.
 - Emulsions that can flow and be pumped, e.g., milk, cream, crèmes, cosmetics, etc.
 - Foams that can flow and be pumped, e.g., desserts, ice-cream, etc.
 - Non-abrasive suspensions that can flow and be pumped, e.g., fruit preparations, etc.
- ⇒ Cleaning agents and disinfectants suitable in principle:
 - Aqueous cleaning base (based on sodium hydroxide solution)
 - Aqueous cleaning acid (based on nitric acid)
 - Aqueous disinfectants (based on peracetic acid)
 - Culinary steam, pure steam, high-quality pure steam (as specified)
- ⇒ Excluded media:
 - Hazardous gaseous media pursuant to the Pressure Equipment Directive 2014/68/EU
 - Radioactive media
 - Toxic and highly toxic media
 - Media harmful to the environment
 - Abrasive media
 - Black steam, unclean steam or steam containing particulate matter
 - Overheated media (liquid media above their evaporation temperatures at atmospheric pressure)

4. Materials and surfaces

4.1. Materials in the product area

Stainless steels	1.4404 (AISI 316 L) 1.4571 (AISI 316Ti) Stainless steel materials with even higher corrosion resistance
Elastomers	EPDM FKM

4.2. Surfaces

Parts in contact with the product	Standard	$R_a \leq 0.8 \mu\text{m}$
	Surface finishes	- e-polished - high-quality surfaces

5. Welding and mounting instructions

5.1. General instructions

Information/notice



Welding work must only be carried out by qualified skilled personnel (DIN EN ISO 9606-1 W8).

Pentair Südmö will not be liable for damages caused as a result of improper use.

5.2. Delivery condition of the disk type non-return valve

- ⇒ Factory-tested
- ⇒ Completely assembled

5.3. Installation guidelines

5.3.1. Installation space

Determine and define the terminal axes before mounting. Refer to the dimension drawings for the installation dimensions.

Ensure that there is sufficient space available for both operation and servicing.

5.3.2. Installation

Exclude tensile and compressive stresses.

5.4. Welding guidelines

Field of application:	Welded connections of weld-on fittings with pipes according to DIN 11850 series 1, 2; ASTM A270; DIN EN ISO 1127
Welding procedure:	TIG (tungsten inert gas welding)
Weld seam:	⇒ Preparation of weld seam according to DIN 2559 (edge forms I / for I seams) ⇒ Weld seams correspond to DIN EN ISO 5817 → Evaluation group B (high)

5.5. Weld seam preparation

- ⇒ Saw off the pipe ends planar at a right angle and debur them (pipe saw M882).
- ⇒ Align the welding ends of the valve body and piping radially and axially for a flush fit (centering device).

Information/notice



- ⇒ Avoid too large a gap at the flush-fitting welding ends.
- ⇒ Make sure that enough forming gas arrives at the welding seam.

5.6. Welding

- ⇒ Connect the forming gas.
- ⇒ Tack at 3 – 4 tack welds.
- ⇒ Weld valve → Type of welding TIG manual or orbital (automatic welding).

5.7. Welding filler

Material allocation

Material of parts to be welded	Suitable welding filler		
	1.4430	1.4440	1.4519
1.4404	X		
1.4435	X	X	X

5.8. Weld seam finishing

5.8.1. Interior

Depending on requirements, for example

- ⇒ untreated.
- ⇒ scotching (at accessible points).

5.8.2. Exterior

Subsequent-treatment procedure

- ⇒ Pickling - ensure proper disposal of pickling paste
- ⇒ Brushing
- ⇒ Grinding
- ⇒ Polishing

5.9. Cleaning of the valve

Clean thoroughly before assembly.

5.10. Valve assembly

Assemble according to the assembly instructions (see chapter “Disassembly - Assembly”).

6. Commissioning of disk type non-return valve



DANGER



- ⇒ The operator of the disk type non-return valves must ensure that those valves where the media connections are not fully integrated into an enclosed pipeline or tank system and therefore can be accessed from outside are provided with devices that reliably prevent such access during commissioning and/or during operation of the valves.
- ⇒ The operator of the fittings must ensure that all people who have access to the disk type non-return valves are made aware of the hazards.



CAUTION



- ⇒ Ensure that no foreign objects are present in the piping system.
- ⇒ Avoid temperature shock!
Warm up the fitting slowly to the operating temperature.

- ⇒ The disk type non-return valves are to be commissioned exclusively by competent and trained commissioning personnel.
- ⇒ The operator of the disk type non-return valves must draw up operating instructions so that all the information required for the commissioning of the valves is available to the operating personnel.
- ⇒ The operator of the disk type non-return valves must ensure that the required safety and limiting systems of the fittings as described in the “limiting systems” chapter are continually functional and that they cannot be switched off whilst operating or changed with respect to their intended use.
- ⇒ Commissioning of the disk type non-return valves includes
 - a wet test, including testing of the valve opening behavior
 - a pressure and sealing test
 - thorough cleaning of the valves, if they are earmarked for processing foodstuffs.
- ⇒ Wet test, opening behavior, pressure and sealing test:
 - Run cold water through the valves.
Opening of the disk type non-return valves must be possible in a secure fashion with a primary pressure of 0.1 bar.
 - Pressurize valves.
To do this, seal the media supply line filled entirely with cold water located downstream of the disk type non-return valves with a suitable isolation valve and apply the test pressure upstream of the disk type non-return valves.
 - Test sealing of fittings by visual check.
 - In case valves are not watertight, de-pressurize, empty and disassemble them.
 - Check the appearance and assembly status of seals; replace seals if necessary.
 - Conduct pressure and sealing test again.
 - Repeat the process as many times as required until there are no further leakages.
- ⇒ Basic cleaning:
If the disk type non-return valves come in contact with foodstuffs, the operator of the valves should clean the fittings thoroughly before food is processed in it.
See the chapter “Cleaning, Disinfection” for this purpose.

7. Maintenance of disk type non-return valves



DANGER



- ⇒ The operator of the fittings must ensure that all people carrying out activities on the fittings are suitably qualified and also able to recognize whether the closing bodies of these fittings are located in their immobile final locations within the fittings. In addition, the operator of the fittings must ensure that these people are instructed not to reach into the media connections on the fittings if this is not already the case.
- ⇒ During servicing, maintenance, and disassembly of the disk type non-return valves, it must be ensured that power-driven switching operations can only be initiated by people working directly on the valves. The operator of the disk type non-return valves must ensure that all people who carry out this activity are suitably qualified and are also able to recognize whether power-driven switching operations on the fittings, apart from by themselves, can be actuated by someone else.

7.1. Inspection of the disk type non-return valve

Disk type non-return valves must be checked at regular intervals and maintained as required.

7.2. Maintenance, troubleshooting and repair of the disk type non-return valve

- ⇒ Maintenance, troubleshooting and repairs may only be executed by competent and trained staff.
- ⇒ Before starting maintenance, troubleshooting or repair work, the fittings must be rinsed with cold water for a sufficient period in order to ensure that no cleaning products or hot water are left behind. The valves are to be emptied thereafter.
- ⇒ Prior to the maintenance, troubleshooting and repair work, the operator of the system in which the disk type non-return valves have been installed, must ensure that the fittings are de-pressurized and cannot be refilled with agents or re-pressurized during the entire period of work.
- ⇒ The operator of the system in which the disk type non-return valves have been installed, must ensure that the system area in which the maintenance, troubleshooting and repair work takes place, has been cordoned off against access by unauthorized persons, and that the exclusion zone will be maintained during the entire period of work.

7.2.1. Seal gaskets

Practice-oriented maintenance intervals can only be determined by the respective user/operator because they depend on the following application parameters:

- ⇒ Operating time per day
- ⇒ Switching intervals
- ⇒ Process parameter (temperature, pressure, flow)
- ⇒ Type of product (fat content, aromas, acids)
- ⇒ Type of cleaning (CIP / SIP / Disinfection)
- ⇒ Sealant

Maintenance intervals of 6-24 months are recommended as a standard value in compliance with the permissible parameters (see chapter "Permissible operating media, pressures and temperatures") and proper use.

8. Cleaning, disinfection

Cleaning and disinfection of the disk type non-return valves may only be done by competent and trained operating staff. If the disk type non-return valves come into contact with food, the operator of the valves must prepare a maintenance plan containing a system of measures to ensure that the required hygiene status of the fittings is maintained within fixed intervals.

These measures include regular cleaning-in-place (short: "CIP") of the valve interior. In some cases, this includes regular "Sanitization-in-place" disinfection (short: "SIP") of the valve interior.

It is characteristic of CIP and SIP processes that they must be carried out when the disk type non-return valves are installed, e.g. together with a pipe cleaning or pipe disinfection or together with the cleaning or disinfection of the system in which the valves are installed.

The disk type non-return valves must not be removed from the system in which they are installed for the purpose of cleaning and disinfection!

Only permissible cleaning and disinfection media within the operating limits specified in chapter "Permissible operating media, pressures and temperatures" may be used!

⇒ Recommended cleaning procedure:

Pre-rinsing (water) - alkaline cleaning - intermediate rinsing (water) - acid cleaning - rinsing (water)

⇒ Recommended procedure for chemical disinfection (only disinfect previously cleaned valves):

Pre-rinsing (water) - disinfection (chemical disinfection medium) - rinsing (sterile water)

⇒ Recommended procedure for thermal disinfection (only disinfect previously cleaned valves):

Rinse (water) - Drain - Disinfect (steam) - Condensate - Rinse (sterile water)

⇒ Recommended cleaning and disinfection parameters

(Temperatures, media, media concentrations, times, flow rates, clock cycles):

Flow rate: > 1.5 m/s

Media, media concentrations, media temperatures: Dependent on the type and extent of contamination, the sealing material in the valve and the frequency of cleaning or disinfection

Cleaning and disinfection times: Dependent on the type and extent of contamination and the frequency of cleaning or disinfection

Operators and maintenance personnel should be instructed to wear appropriate protective clothing (e.g. gloves, goggles) during automatic CIP and SIP processes!

The maintenance plans for cleaning and/or disinfection are to be validated by the operator of the disk type non-return valves in accordance with their requirements.

9. Operating equipment and auxiliary media

9.1. External cleaner (foam, gel or spray cleaner for external cleaning of disk type non-return valves)

Compatibility of the external cleaner used with the surface materials of the disk type non-return valves (stainless steels, plastics) must be ensured.

10. Decommissioning

- ⇒ Decommissioning the disk type non-return valves can be done with or without disassembly. In case of decommissioning with disassembly, all disassembly steps described in the respective relevant operating instructions should be additionally observed.
- ⇒ Before starting with a decommissioning, the disk type non-return valves must be rinsed with cold water for a sufficient period in order to ensure that no cleaning products or hot water can be found. The valves are to be emptied thereafter.
- ⇒ Prior to decommissioning without disassembly, the operator of the disk type non-return valves must ensure that the fittings remain de-pressurized for a long time and cannot be refilled with agents or re-pressurized.
- ⇒ When decommissioning, physically separate disk type non-return valves from all media pipelines that could be used to inadvertently supply media to the fittings!

11. Disposal

- ⇒ The disk type non-return valves must be disassembled in accordance with the disassembly steps described in the operating instructions (See the "Disassembly – Assembly" chapter).
- ⇒ Dispose of disk type non-return valves according to local provisions and guidelines in country of use

12. Technical data

12.1. Dimensions

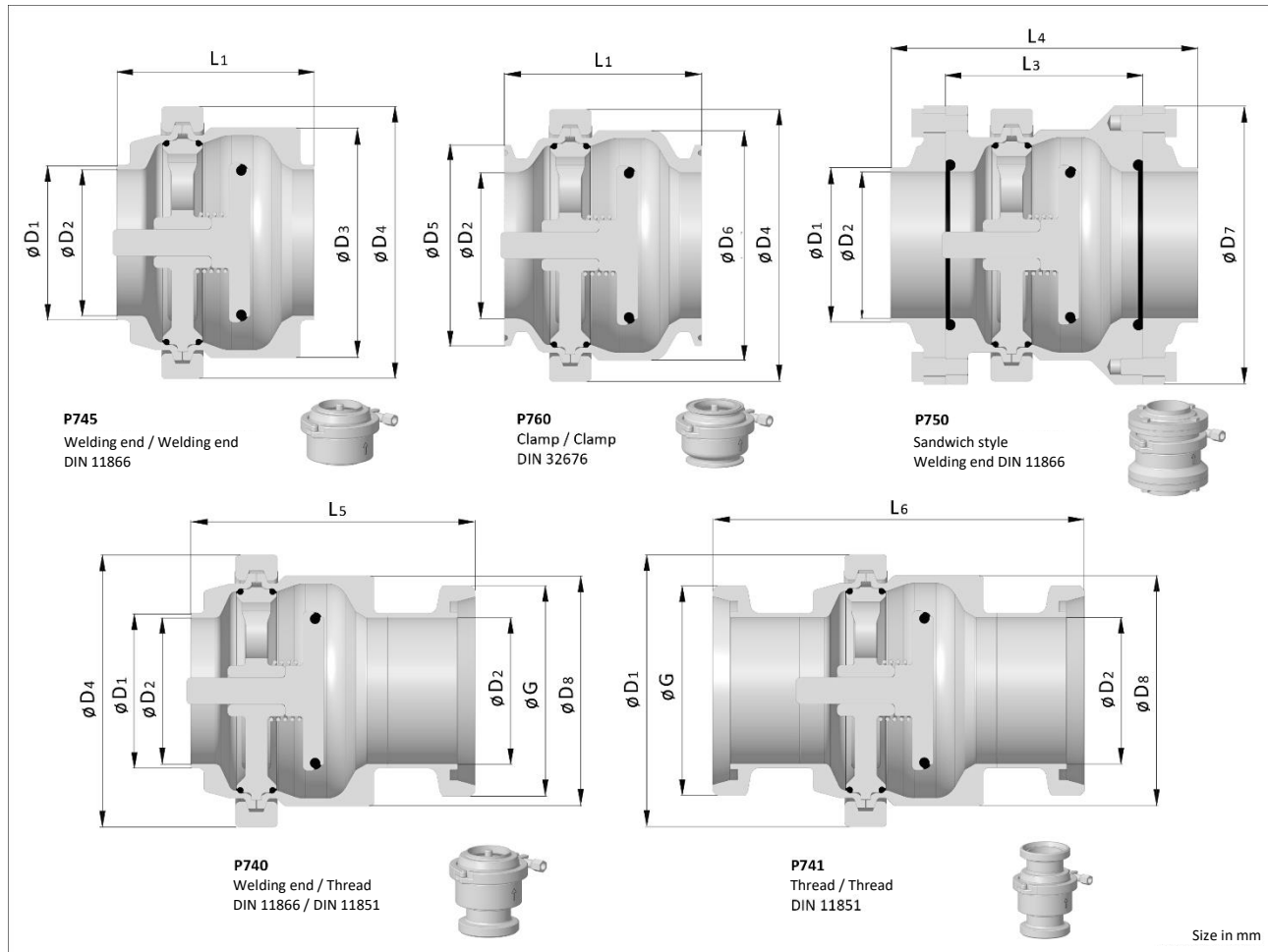

DN	Pipe ϕ	$\phi D1$	$\phi D2$	$\phi D3$	$\phi D4$	$\phi D5$	$\phi D6$	$\phi D7$	$\phi D8$	ϕG	L1	L2	L3	L4	L5	L6
DN 010	13 x 1.5	13.0	10.0	43.0	65.0	34.0	43.0	62.5	43.0	Rd 28 x 1/8"	68.0	64.0	60.0	110.0	88.5	109.0
DN 015	19 x 1.5	19.0	16.0	43.0	65.0	34.0	43.0	62.5	43.0	Rd 34 x 1/8"	52.0	64.0	60.0	110.0	82.5	103.0
DN 020	23 x 1.5	23.0	20.0	43.0	65.0	34.0	43.0	62.5	43.0	Rd 44 x 1/6"	52.0	64.0	60.0	110.0	85.5	109.0
DN 025	29 x 1.5	29.0	26.0	55.0	77.0	50.5	55.0	84.0	55.0	Rd 52 x 1/6"	75.0	75.0	75.0	125.0	103.5	132.0
DN 040	41 x 1.5	41.0	38.0	68.5	92.0	50.5	68.5	96.0	68.5	Rd 65 x 1/6"	80.0	80.0	80.0	130.0	112.5	145.0
DN 050	53 x 1.5	53.0	50.0	85.0	104.0	64.0	85.0	109.0	85.0	Rd 78 x 1/6"	82.5	82.5	82.5	132.5	117.0	151.5
DN 065	70 x 2.0	70.0	66.0	104.0	123.0	91.0	104.0	126.0	104.0	Rd 95 x 1/6"	89.0	89.0	89.0	139.0	128.5	168.0
DN 080	85 x 2.0	85.0	81.0	126.0	130.0	106.0	126.0	141.0	126.0	Rd 110 x 1/4"	99.0	99.0	99.0	149.0	143.5	188.0
DN 100	104 x 2.0	104.0	100.0	153.0	159.0	119.0	153.0	161.0	153.0	Rd 130 x 1/4"	114.0	114.0	114.0	164.0	167.5	221.0
DN 125	129 x 2.0	129.0	125.0	190.0	203.0	155.0	190.0	200.0	190.0	Rd 160 x 1/4"	146.0	146.0	138.0	198.0	191.5	237.0
DN 150	154 x 2.0	154.0	150.0	227.0	241.0	183.0	227.0	230.0	227.0	Rd 190 x 1/4"	162.5	162.5	152.5	212.5	212.0	261.5

Operating Instructions

Disk type non-return valves

RV Solid series

Type: P740, P741, P745, P750 and P760

DN 010 – 150, OD 0.50" – 6.00", ISO 008 – 125

DN	Pipe ø	øD1	øD2	øD3	øD4	øD5	øD6	øD7	øD8	øG	L1	L2	L3	L4	L5	L6
OD 0.50"	12.70 x 1.65	12.70	9.40	43.0	65.0	25.0	43.0	62.5	-----	-----	68.0	67.0	60.0	110.0	-----	-----
OD 0.75"	19.05 x 1.65	19.05	15.75	43.0	65.0	25.0	43.0	62.5	-----	-----	64.0	67.0	60.0	110.0	-----	-----
OD 1.00"	25.40 x 1.65	25.40	22.10	55.0	77.0	50.5	55.0	84.0	-----	-----	78.0	75.0	75.0	125.0	-----	-----
OD 1.50"	38.10 x 1.65	38.10	34.80	68.5	92.0	50.5	68.5	96.0	-----	-----	82.0	80.0	80.0	130.0	-----	-----
OD 2.00"	50.80 x 1.65	50.80	47.50	85.0	104.0	64.0	85.0	109.0	-----	-----	84.5	82.5	82.5	132.5	-----	-----
OD 2.50"	63.50 x 1.65	63.50	60.20	104.0	123.0	77.5	104.0	126.0	-----	-----	94.0	94.0	94.0	144.0	-----	-----
OD 3.00"	76.20 x 1.65	76.20	72.90	126.0	130.0	91.0	126.0	141.0	-----	-----	104.0	104.0	104.0	154.0	-----	-----
OD 4.00"	101.60 x 2.11	101.60	97.38	153.0	159.0	119.0	153.0	161.0	-----	-----	116.0	114.0	114.0	164.0	-----	-----
OD 6.00"	152.40 x 2.77	152.40	146.86	227.0	241.0	167.0	227.0	230.0	-----	-----	164.5	162.5	152.5	212.5	-----	-----
ISO 008	13.5 x 1.6	13.50	10.30	43.0	65.0	25.0	43.0	62.5	-----	-----	68.0	67.0	60.0	110.0	-----	-----
ISO 010	17.2 x 1.6	17.20	14.00	43.0	65.0	25.0	43.0	62.5	-----	-----	64.0	67.0	60.0	110.0	-----	-----
ISO 015	21.3 x 1.6	21.30	18.10	43.0	65.0	50.5	43.0	62.5	-----	-----	62.0	64.0	60.0	110.0	-----	-----
ISO 020	26.9 x 1.6	26.90	23.70	55.0	77.0	50.5	55.0	84.0	-----	-----	75.0	75.0	75.0	125.0	-----	-----
ISO 025	33.7 x 2.0	33.70	29.70	68.5	92.0	50.5	68.5	96.0	-----	-----	85.0	80.0	80.0	130.0	-----	-----
ISO 040	48.3 x 2.0	48.30	44.30	85.0	104.0	64.0	85.0	109.0	-----	-----	82.5	82.5	82.5	132.5	-----	-----
ISO 050	60.3 x 2.0	60.30	56.30	104.0	123.0	77.5	104.0	126.0	-----	-----	94.0	99.0	89.0	139.0	-----	-----
ISO 065	76.1 x 2.0	76.10	72.10	126.0	130.0	91.0	126.0	141.0	-----	-----	104.0	104.0	99.0	149.0	-----	-----
ISO 080	88.9 x 2.3	88.90	84.30	153.0	159.0	106.0	148.0	161.0	-----	-----	123.0	133.0	114.0	164.0	-----	-----
ISO 100	114.3 x 2.3	114.30	109.70	183.0	203.0	130.0	183.0	200.0	-----	-----	151.0	165.0	138.0	198.0	-----	-----
ISO 125	139.7 x 2.6	139.70	134.50	217.4	241.0	155.0	217.4	230.0	-----	-----	167.5	180.0	152.5	212.5	-----	-----

12.2. Weights

Weights (kg)											
Valve type	DN 010	DN 015	DN 020	DN 025	DN 040	DN 050	DN 065	DN 080	DN 100	DN 125	DN 150
P740	0.77	0.72	0.77	1.19	1.67	2.20	3.04	4.26	6.04	11.50	17.40
P741	0.81	0.78	0.87	1.33	1.87	2.46	3.45	4.88	6.81	12.66	19.32
P745	0.73	0.66	0.66	1.06	1.48	1.94	2.64	3.65	5.23	10.33	15.44
P750	1.64	1.67	1.65	2.91	3.69	4.54	5.74	7.02	9.27	18.22	24.94
P760	0.64	0.62	0.60	1.02	1.26	1.66	2.42	3.19	4.34	9.39	13.74
Valve type	OD 0.50"	OD 0.75"	OD 1.00"	OD 1.50"	OD 2.00"	OD 2.50"	OD 3.00"	OD 4.00"	OD 6.00"		
P745	0.73	0.70	1.11	1.54	2.02	2.89	4.03	5.50	15.96		
P750	1.65	1.66	2.98	3.77	4.62	6.32	7.77	9.44	25.07		
P760	0.62	0.61	1.04	1.29	1.70	2.34	3.14	4.29	12.67		
Valve type	ISO 008	ISO 010	ISO 015	ISO 020	ISO 025	ISO 040	ISO 050	ISO 065	ISO 080	ISO 100	ISO 125
P745	0.73	0.67	0.66	1.06	1.62	1.97	2.91	4.04	6.29	10.89	15.72
P750	1.66	1.66	1.66	2.92	3.75	4.60	5.86	7.16	9.52	18.68	25.48
P760	0.63	0.63	0.78	1.03	1.32	1.71	2.46	3.16	5.12	9.83	13.89



12.3. Valve use

Application:	disk type non-return valve
Use:	hygienic processes
Shut-off tightness:	10 bar (145 psi) max.

Information/notice



- ⇒ If the column of water is less than 2 m in height (0.2 bar pressure), this may result in a slight leak from the seal seat of the valve.
- ⇒ Please refer to the "Disassembly - Assembly" chapter for details of how to carefully mount the O-ring.

13. Valve connection piping

13.1. Installation position

- ⇒ Preferred installation position: vertical

Information/notice



- ⇒ If the installation position is horizontal, increased wear and tear should be expected depending on the operating conditions.

13.2. Valve connections

- | | |
|--------------|---|
| Connections: | <ul style="list-style-type: none">- Welding end
→ Detachable connection required for maintenance- Threaded connection- Clamp connection- Small-flange connection |
|--------------|---|

For welding instructions, refer to the "Welding and Mounting Instructions" chapter.

13.3. Installation details for disk type non-return valves

- ⇒ Disk type non-return valve as per the assembly instructions.
- ⇒ Weld or mount the disk type non-return valve into the pipeline.

Information/notice



Welding instruction

- ⇒ Dismantle the seals before welding.
- ⇒ Shrink-wrap valve body free from tension and distortions.
- ⇒ Welding work must only be carried out by qualified skilled personnel (DIN EN ISO 9606-1 W8).

Assembly instructions

- ⇒ No foreign matter must remain in the pipeline when the valves are assembled.

- ⇒ For assembly instructions, refer to the "Disassembly - Assembly" chapter.

14. Disassembly – Assembly

As a general rule, assemble the disk type non-return valve in accordance with the hazard notes (refer to the chapter "Preparatory Measures for Disassembly – Assembly").

14.1. Preparatory measures for disassembly – assembly

Before disconnecting the valve connections and the clamp connection of the valve body, the following steps must always be carried out:



WARNING



- ⇒ The disk type non-return valves must only be assembled by trained and qualified personnel.
 - Training or instruction according to the current standards of the safety regulations.
 - For systems with explosion protection: training or instruction or authorization to carry out work on the systems subject to explosion hazards (observe ATEX regulations).
- ⇒ Get information on possible risks that could be caused by residues of the operating material and take appropriate measures if necessary (safety gloves, safety goggles etc.), before carrying out maintenance and service work on the disk type non-return valve.
- ⇒ Before disconnecting the valve connections and the clamp connection of the valve body, make sure that
 - the work is only carried out in a depressurized state and with the media supply shut off.
 - the disk type non-return valve and all piping elements leading to the valve have been drained, cleaned or rinsed.
 - the fittings have cooled down.
 - the commissioning of the system by a third party is ruled out.
 - The pressure build-up which may form in pipelines is counteracted.
 - the disk type non-return valve is disassembled - assembled according to the assembly instructions.
 - the disk type non-return valve is removed from the pipeline section, if possible.

Information/notice



- ⇒ Cordon off assembly area.
- ⇒ Ensure that the assembly area remains cordoned off while work is being carried out.

14.2. Spare parts

Information/notice







Only use original spare parts.

⇒ Original spare parts, see spare parts of the respective disk type non-return valve.

⇒ Smooth operation of the disk type non-return valve is only guaranteed when using original spare parts.

14.3. Assembly tools

Quantity	Tool		for	Order no.
1	Double open ended wrench (wrench size) 14 – 15		All sizes All valve types	2112345
1	Double open ended wrench (wrench size) 17 – 19		All sizes All valve types	2112372
1	Punch 155 mm		All sizes All valve types	0098525
1	Torque wrench with socket wrench (wrench size 17)		All sizes All valve types	
2	Brush (small) S400 g. 2		All sizes All valve types	0050799

14.4. Assembly of joint clamp

Information/notice

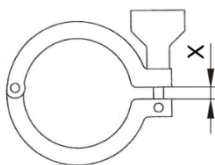

Fig. 1



Fig. 2

⇒ Only install the clamp in perfect technical condition (Fig. 1)

→ No visible deformations (for example bent feet, bent forks, etc.)

⇒ The clamping feet are not permitted to touch after tightening (Fig. 2).

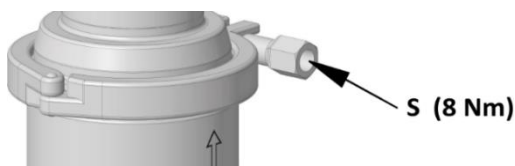

Fig. 3

⇒ Grease screw thread before assembly → grease type IBF PW 119

⇒ Place clamp on clamp connection.

⇒ Insert screw with hexagonal nut (S) into the groove of the fork.

⇒ Tighten the hexagon nut (S) with a torque wrench → Tightening torque 8 Nm.

14.5. Assembling the O-rings

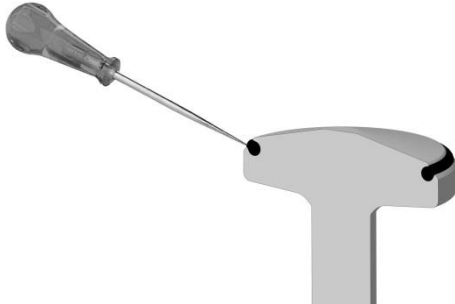

14.5.1. Dismantling the O-rings

- ⇒ O-ring is installed in positive contact under pretension.
- ⇒ Disassemble as shown.

Information/notice

-  ⇒ Do not damage the seal groove (edges of the groove).

Caution

-  ⇒ Do not slip off with the punch.
→ Risk of injury.

14.5.2. Installing the O-rings

- ⇒ Fasten O-ring in a crosswise sequence (in the order 1 - 2, 3 - 4 etc.) in four positions in the groove.
- ⇒ Roll the O-ring (section by section 1 - 6, 5 - 2 etc.) into the groove with light rolling movements on a clean surface.
- ⇒ Use a plastic surface for the assembly (if possible, avoid surfaces made of wood or metal).

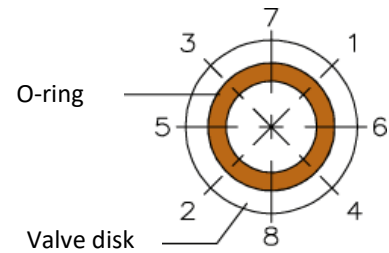

Information/notice

-  ⇒ Avoid twisting and damaging the O-ring.

14.6. Replacement of the seals in contact with the product

14.6.1. Disk type non-return valve, type P740, P741, P745 and P760

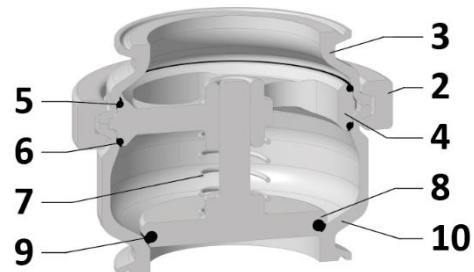
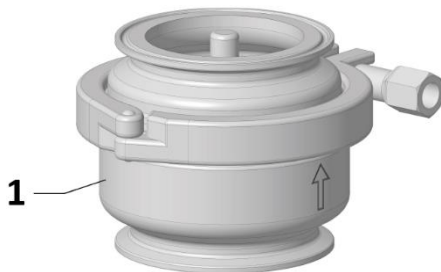

Valve disassembly

- I.1. Disconnect the disk type non-return valve (1).
- I.2. Disassemble the clamp (2).

I.3. Remove the housing lid (3).

Information/notice	
	⇒ Be aware of the spring tensioning pressure.

I.4. Remove spring guide (4) and dismount O-rings (5, 6).

I.5. Remove pressure springs (7).

I.6. Remove valve disk (8).

I.7. Dismount O-ring (9).

Valve assembly

I.8. Prior to assembly, clean and grease the shafts and sliding surfaces.

Sealing materials	Lubricant type
EPDM	PARALIQ GTE 703 (P) apply a thin layer at the perimeter with a brush
FKM	PARALIQ GTE 703 (P) apply a thin layer at the perimeter with a brush

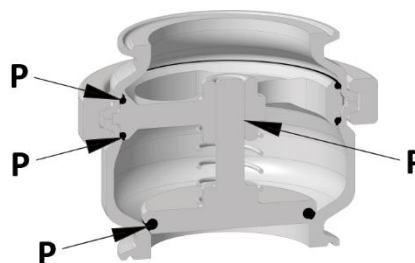

Information/notice	
	⇒ If a different grease is used → Corrosion of the sealing elements. ⇒ Do not use mineral greases and animal fats. ⇒ Do not use any petroleum-based fats.

I.9. Mount O-ring (9) on to valve disk (8).

I.10. Position valve disk (8) in the valve body (10).

I.11. Mount pressure springs (7) on to valve disk (8).

I.12. Mount O-rings (5, 6) on to spring guide (4).

I.13. Mount spring guide (4) on to valve body (10).

I.14. Position housing lid (3) on to valve body (10).

I.15. Assemble and fasten clamp (2) - tightening torque 8 Nm.

I.16. Mount disk type non-return valve (1) on to piping system.

14.6.2. Disk type non-return valve, type P750

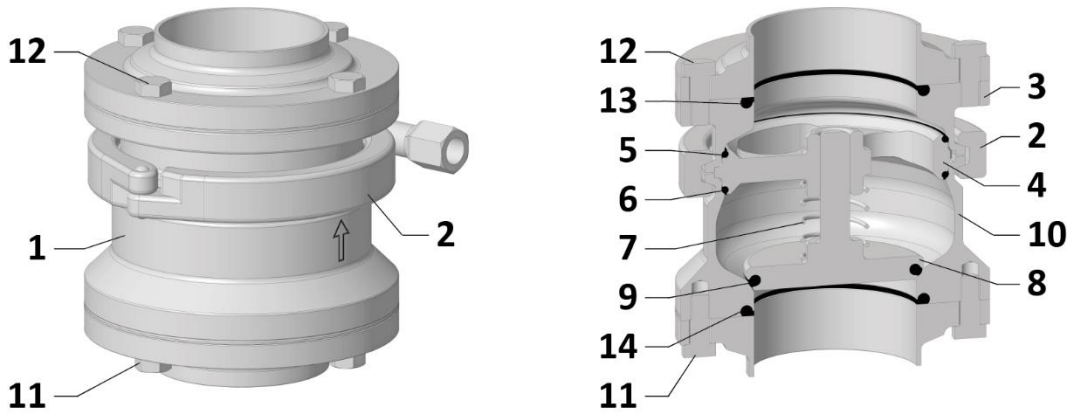

Valve disassembly

- II.1. Dismantle screws (11, 12) and remove disk type non-return valve (1) from piping system.
- II.2. Disassemble the clamp (2).
- II.3. Remove the housing lid (3).

Information/notice	
	⇒ Be aware of the spring tensioning pressure.

- II.4. Remove spring guide (4) and dismount O-rings (5, 6).
- II.5. Remove pressure springs (7).
- II.6. Remove valve disk (8).
- II.7. Dismount O-ring (9).

Valve assembly

- II.8. Prior to assembly, clean and grease the shafts and sliding surfaces.

Sealing materials	Lubricant type
EPDM	PARALIQ GTE 703 (P) apply a thin layer at the perimeter with a brush
FKM	PARALIQ GTE 703 (P) apply a thin layer at the perimeter with a brush

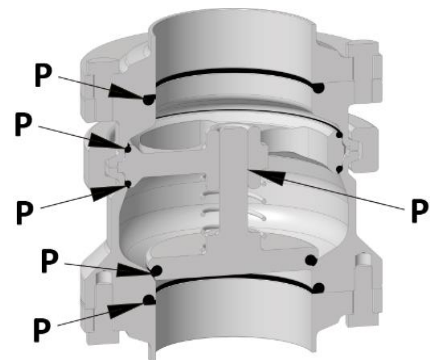

Information/notice	
	⇒ If a different grease is used → Corrosion of the sealing elements. ⇒ Do not use mineral greases and animal fats. ⇒ Do not use any petroleum-based fats.

- II.9. Mount O-ring (9) on to valve disk (8).
- II.10. Position valve disk (8) in the valve body (10).
- II.11. Mount pressure springs (7) on to valve disk (8).
- II.12. Mount O-rings (5, 6) on to spring guide (4).
- II.13. Mount spring guide (4) on to valve body (10).
- II.14. Position housing lid (3) on to valve body (10).

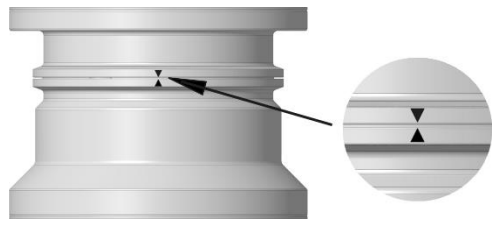
Information/notice	
	<p>⇒ When mounting, pay attention to ensure that the markings on the valve body (10) and the housing lid (3) are on top of each other.</p>
	

- II.15. Assemble and fasten clamp (2) - tightening torque 8 Nm.
- II.16. Insert disk type non-return valve (1) into piping system and assemble screws (11, 12).

15. Malfunctions – troubleshooting

WARNING



- ⇒ Never touch the valve or pipelines if hot media are being processed or if the sterilization process is running.
- ⇒ Operating parameters (see "Permissible operating media, pressures and temperatures") must always be strictly observed.

CAUTION



- ⇒ Malfunctions must only be eliminated by qualified and trained personnel while observing the safety regulations.

Malfunctions	Cause	Troubleshooting
Valve does not close	⇒ Dirt / foreign objects in the seat area	<ul style="list-style-type: none"> ⇒ Clean the valve body and sealing area of the valve disk/closing sleeve ⇒ Grease seals <ul style="list-style-type: none"> → See grease diagram ⇒ Replace seals and pressure springs
	⇒ Spring fracture	<ul style="list-style-type: none"> ⇒ Replace pressure springs <ul style="list-style-type: none"> → Pressure spring forms part of the seal set

16. Replacement parts lists

16.1. Disk type non-return valve, type P740, P741, P745 and P760

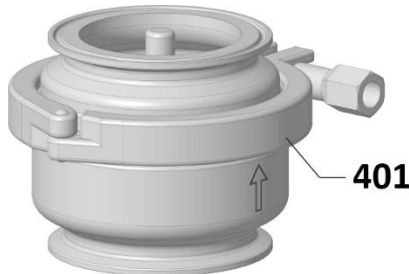

Wearing part kits kpl:

Item	Description	Number of units	Material	Material No.			
				DN 010	DN 015	DN 020	DN 025
				ISO 008	OD 0.50"	OD 0.75"	OD 1.00"
					ISO 010	ISO 015	ISO 020
	Product side consisting of:	1	EPDM	2148403	2148403	2148403	2148427
			FKM	2350110	2350110	2350110	2350111
101	O-ring	1	EPDM				
			FKM				
102	O-ring	2	EPDM				
			FKM				
103	Pressure spring	1	1.4571				
				DN 040	DN 050	DN 065	DN 080
				OD 1.50"	OD 2.00"	OD 2.50"	OD 3.00"
				ISO 025	ISO 040	ISO 050	ISO 065
	Product side consisting of:	1	EPDM	2148428	2148429	2148442	2148443
			FKM	2350112	2350113	2350114	2350115
101	O-ring	1	EPDM				
			FKM				
102	O-ring	2	EPDM				
			FKM				
103	Pressure spring	1	1.4571				
				DN 100	DN 125	DN 150	
				OD 4.00"		OD 6.00"	
				ISO 080	ISO 100	ISO 125	
	Product side consisting of:	1	EPDM	2148444	2148419	2148420	
			FKM	2350116	2350117	2350118	
101	O-ring	1	EPDM				
			FKM				
102	O-ring	2	EPDM				
			FKM				
103	Pressure spring	1	1.4571				

Operating Instructions

Disk type non-return valves

RV Solid series

Type: P740, P741, P745, P750 and P760

DN 010 – 150, OD 0.50" – 6.00", ISO 008 – 125

Other individual parts:

Item	Description	PB ¹⁾	NPB ²⁾	Number of units	Material	Material No.			
						DN 010 ISO 008	DN 015 OD 0.50" ISO 010	DN 020 OD 0.75" ISO 015	DN 025 OD 1.00" ISO 020
	Set of Spare parts 'containing of					2148705	2148705	2148705	2148706
301	Valve disk	X		1	1.4404				
302	Guide starwheel	X		1	1.4404				
401	Terminal		X	1	1.4301	0034421DN	0034421DN	0034421DN	0034439I
	Set of Spare parts containing of:					2148707	2148708	2148709	2148710
301	Valve disk	X		1	1.4404				
302	Guide starwheel	X		1	1.4404				
401	Terminal		X	1	1.4301	0034447I	0034587I	0036590I	0034595I
	Set of Spare parts containing of:					2148711	2148712	2148713	
301	Valve disk	X		1	1.4404				
302	Guide starwheel	X		1	1.4404				
401	Terminal		X	1	1.4301	2142225	2111992	2130160	

- 1) PB:
in contact with product
- 2) NPB:
not in contact with product

Notes:

- Material No.s for individual parts in contact with the product (3xx) meet our catalog standard (material, surface, etc.).
- When inquiring about wear and individual parts, please always indicate the material number of the complete valve. See label on the valve or order confirmation.
- Seals in contact with the product meet the provisions of the FDA and EC 1935 Certificates on request



Operating Instructions

Disk type non-return valves

RV Solid series

Type: P740, P741, P745, P750 and P760

DN 010 – 150, OD 0.50" – 6.00", ISO 008 – 125

16.2. Disk type non-return valve, type P750

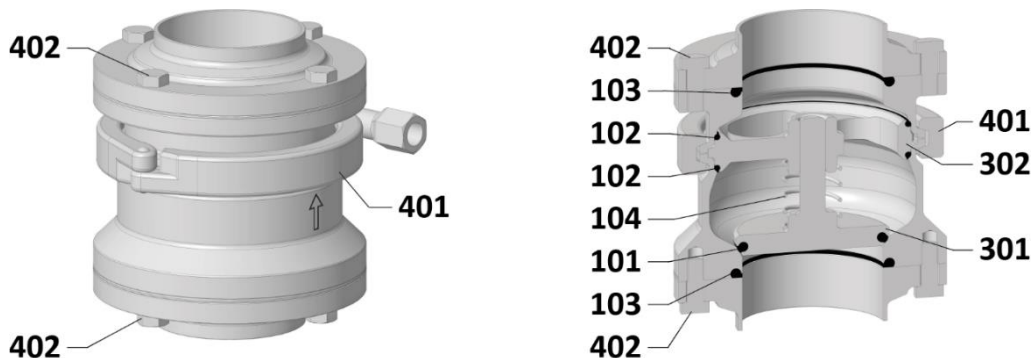

Wearing part kits kpl:

Item	Description	Number of units	Material	Material No.			
				DN 010	DN 015	DN 020	DN 025
				DN 010	DN 015	DN 020	DN 025
	Product side consisting of:	1	EPDM	2148414	2148414	2148414	2148445
			FKM	2350119	2350119	2350119	2350120
101	O-ring	1	EPDM				
			FKM				
102	O-ring	2	EPDM				
			FKM				
103	O-ring	2	EPDM				
			FKM				
104	Pressure spring	1	1.4571				
				DN 040	DN 050	DN 065	DN 080
	Product side consisting of:	1	EPDM	2148446	2148447	2148448	2148449
			FKM	2350121	2350122	2350123	2350124
101	O-ring	1	EPDM				
			FKM				
102	O-ring	2	EPDM				
			FKM				
103	O-ring	2	EPDM				
			FKM				
104	Pressure spring	1	1.4571				
				DN 100	DN 125	DN 150	
	Product side consisting of:	1	EPDM	2148450	2148451	2148452	
			FKM	2350125	2350126	2350127	
101	O-ring	1	EPDM				
			FKM				
102	O-ring	2	EPDM				
			FKM				
103	O-ring	2	EPDM				
			FKM				
104	Pressure spring	1	1.4571				



Operating Instructions

Disk type non-return valves

RV Solid series

Type: P740, P741, P745, P750 and P760

DN 010 – 150, OD 0.50" – 6.00", ISO 008 – 125

Item	Description	Number of units	Material	Material No.			
				OD 0.50"	OD 0.75"	OD 1.00"	OD 1.50"
				OD 0.50"	OD 0.75"	OD 1.00"	OD 1.50"
	Product side consisting of:	1	EPDM	2148414	2148414	2148453	2148454
			FKM	2350119	2350119	2350128	2350129
101	O-ring	1	EPDM				
			FKM				
102	O-ring	2	EPDM				
			FKM				
103	O-ring	2	EPDM				
			FKM				
104	Pressure spring	1	1.4571				
				OD 2.00"	OD 2.50"	OD 3.00"	OD 4.00"
	Product side consisting of:	1	EPDM	2148455	2148456	2148457	2148457
			FKM	2350130	2350131	2350132	2350132
101	O-ring	1	EPDM				
			FKM				
102	O-ring	2	EPDM				
			FKM				
103	O-ring	2	EPDM				
			FKM				
104	Pressure spring	1	1.4571				
				OD 6.00"			
	Product side consisting of:	1	EPDM	2148452			
			FKM	2350127			
101	O-ring	1	EPDM				
			FKM				
102	O-ring	2	EPDM				
			FKM				
103	O-ring	2	EPDM				
			FKM				
104	Pressure spring	1	1.4571				
				ISO 008	ISO 010	ISO 015	ISO 020
	Product side consisting of:	1	EPDM				
			FKM				
101	O-ring	1	EPDM				
			FKM				
102	O-ring	2	EPDM				
			FKM				
103	O-ring	2	EPDM				
			FKM				
104	Pressure spring	1	1.4571				



Operating Instructions

Disk type non-return valves

RV Solid series

Type: P740, P741, P745, P750 and P760

DN 010 – 150, OD 0.50" – 6.00", ISO 008 – 125

Item	Description	Number of units	Material	Material No.			
				ISO 025	ISO 040	ISO 050	ISO 065
	Product side consisting of:	1	EPDM				
			FKM				
101	O-ring	1	EPDM				
			FKM				
102	O-ring	2	EPDM				
			FKM				
103	O-ring	2	EPDM				
			FKM				
104	Pressure spring	1	1.4571				
				ISO 080	ISO 100	ISO 125	
	Product side consisting of:	1	EPDM				
			FKM				
101	O-ring	1	EPDM				
			FKM				
102	O-ring	2	EPDM				
			FKM				
103	O-ring	2	EPDM				
			FKM				
104	Pressure spring	1	1.4571				

Other individual parts:

						DN 010	DN 015	DN 020	DN 025
						ISO 008	OD 0.50" ISO 010	OD 0.75" ISO 015	OD 1.00" ISO 020
	Set of Spare parts containing of:					2148705	2148705	2148705	2148706
301	Valve disk	X		1	1.4404				
302	Guide starwheel	X		1	1.4404				
401	Terminal		X	1	1.4301	0034421DN	0034421DN	0034421DN	0034439I
402	Set of Screws		X	1	A 2-70	2148714	2148714	2148714	2148715
						DN 040	DN 050	DN 065	DN 080
						OD 1.50" ISO 025	OD 2.00" ISO 040	OD 2.50" ISO 050	OD 3.00" ISO 065
	Set of Spare parts containing of:					2148705	2148705	2148705	2148706
301	Valve disk	X		1	1.4404				
302	Guide starwheel	X		1	1.4404				
401	Terminal		X	1	1.4301	0034447I	0034587I	0036590I	2161086
402	Set of Screws		X	1	A 2-70	2148415	2148415	2148415	2148415



Operating Instructions

Disk type non-return valves

RV Solid series

Type: P740, P741, P745, P750 and P760

DN 010 – 150, OD 0.50" – 6.00", ISO 008 – 125

Item	Description	PB ¹⁾	NPB ²⁾	Number of units	Material	Material No.			
						DN 100 OD 4.00" ISO 080	DN 125 ISO 100	DN 150 OD 6.00" ISO 125	
	Set of Spare parts containing of:					2148711	2148712	2148713	
301	Valve disk	X		1	1.4404				
302	Guide starwheel	X		1	1.4404				
401	Terminal		X	1	1.4301	2142225	2111992	2130160	
402	Set of Screws		X	1	A 2-70	2148716	2148717	2148717	

- 1) PB:
in contact with product
- 2) NPB:
not in contact with product

Notes:

- Material No.s for individual parts in contact with the product (3xx) meet our catalog standard (material, surface, etc.).
- When inquiring about wear and individual parts, please always indicate the material number of the complete valve. See nameplate on the valve or order confirmation.
- Seals in contact with the product meet the provisions of the FDA and EC 1935
- Certificates on request

Operating Instructions

Disk type non-return valves

RV Solid series

Type: P740, P741, P745, P750 and P760

DN 010 – 150, OD 0.50" – 6.00", ISO 008 – 125

Operating Instructions

Disk type non-return valves

RV Solid series

Type: P740, P741, P745, P750 and P760

DN 010 – 150, OD 0.50" – 6.00", ISO 008 – 125

17. Service address

Pentair Südmo GmbH

Industriestraße 7

73469 Riesbürg - Germany

Tel: +49 (0) 9081-803-0

Fax : +49 (0) 9081-803-158

E info.suedmo@pentair.com

I www.suedmo.de

© 2023 Pentair Südmo GmbH

Technical data subject to change without notice

