



## CHARACTERISTICS

- DUAL PUMP MODULES AS STANDARD FOR MAXIMUM UPTIME AND REDUNDANCY.
- HIGH PRESSURE AND FLOW RATE FOR VERY EXTENSIVE SYSTEMS
- 380 CM<sup>3</sup>/MIN (2x 190 CM<sup>3</sup>/MIN PER MODULE)
- 400 BAR (5800 PSI)
- ELECTRICAL DUAL LINE INVERTER INTEGRATES DIRECTLY ONTO OUTLET.
- MINIMUM LEVEL CAPACITANCE SWITCH AND VISUAL MAXIMUM LEVEL AS STANDARD.
- HANDLES-GREASE NLGI 2.
- SUPPLIED ON A FIXING PALLET AS STANDARD FOR EASE OF TRANSPORTATION- AND INSTALLATION.

## APPLICATIONS

- HEAVY DUTY APPLICATIONS IN DEMANDING ENVIRONMENTS
- STEEL INDUSTRY
- PULP & PAPER
- CEMENT WORKS
- STEEL PLANT
- OFF-SHORE
- LARGE CRANES AND LOADING EQUIPMENT

## ELECTRIC PUMP SOLUTION SUMO II

### THE FLEXIBLE HIGH PERFORMANCE HEAVY DUTY

#### DUAL PUMPING MODULE

The **SUMO II** pump is the ideal electric DropsA pump for use with dual-line systems.

The two pumps installed using the dual configuration guarantees a maximum pressure of 400 bar in redundancy mode. Configured in this way, it also works even if one of the two pumps should stop.

#### INSTRUMENTATION AND MODULES

SUMO II can be equipped with sophisticated additional modules to adapt the pump to complex applications using DropsA standard products.

#### QUICK SWAP SYSTEM

Both **PUMPING MODULES** can be quickly replaced. In fact, it not necessary to take any action on the pipework and connections, reducing downtime during maintenance to practically zero.

#### DUAL LINE OR SINGLE LINE IS EASY

The outlet plate fixing system has both Pressure and Return ports. The outlets are directly compatible with Dropsa's electrical or pneumatic line inverters (including Modular version).



## DUAL LINE SYSTEM

### SIMPLE AND RELIABLE PARTICULARLY IN HARSH ENVIRONMENTAL

The lubrication systems designed with the dual-line system are generally used for lubricating several points on over-size machinery and in uncomfortable functioning conditions.

The system can grow to a very complex one with a length that often can exceed 60 meters. The large section of pump packages together with many custom design options allows any lubrication system to be developed reliably and cost-effectively.

### ADVANTAGES:

1. Can be used at high pressures.
2. Easily to expand or modify the system
3. The modular elements allow for the element to be changed quickly without disconnecting the pipework.
4. In the event that a point to be lubricated becomes blocked or is not adequately lubricated, the rest of the system is not influenced and continues to operate normally.

### PRESSURISATION LINE 1

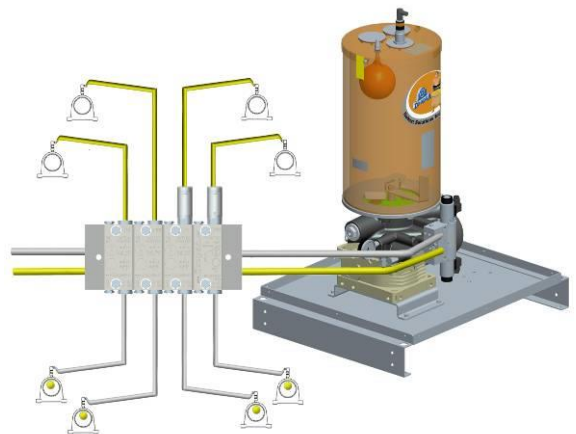

### PRESSURISATION LINE 2

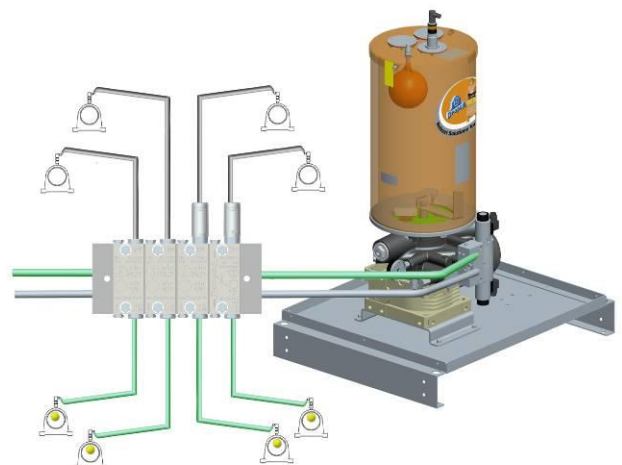



TECHNICAL INFORMATION

TECHNICAL CHARACTERISTICS

Max pressure	5800 psi (400 bar)
Output Flow Delivery	380 cm <sup>3</sup> / min (22.8 cu. in/min) total (standard) 190 cm <sup>3</sup> (11.59 cu. in) single pumping
Operating Temperature	- 10 ÷ + 50 °C (+14÷122F)
Operating Humidity	90% max
Protection grade	IP 55
Viscosity at operating temperature	Mineral oil lubricants Min. 32 cSt max. 1000 cSt

DIMENSIONS

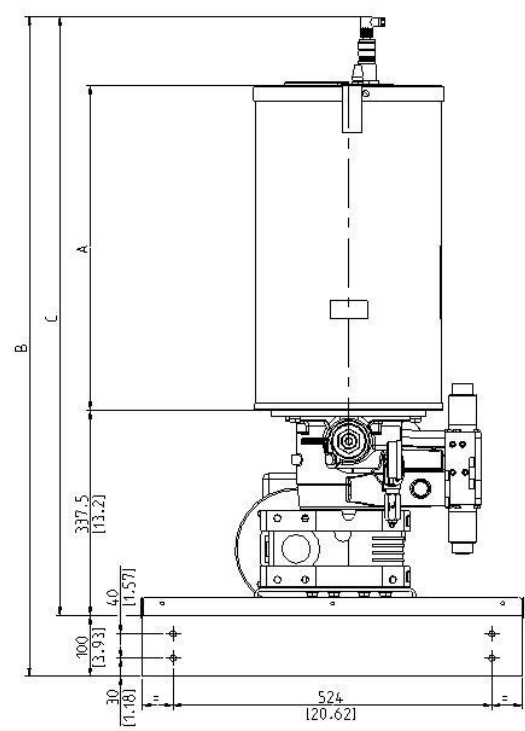
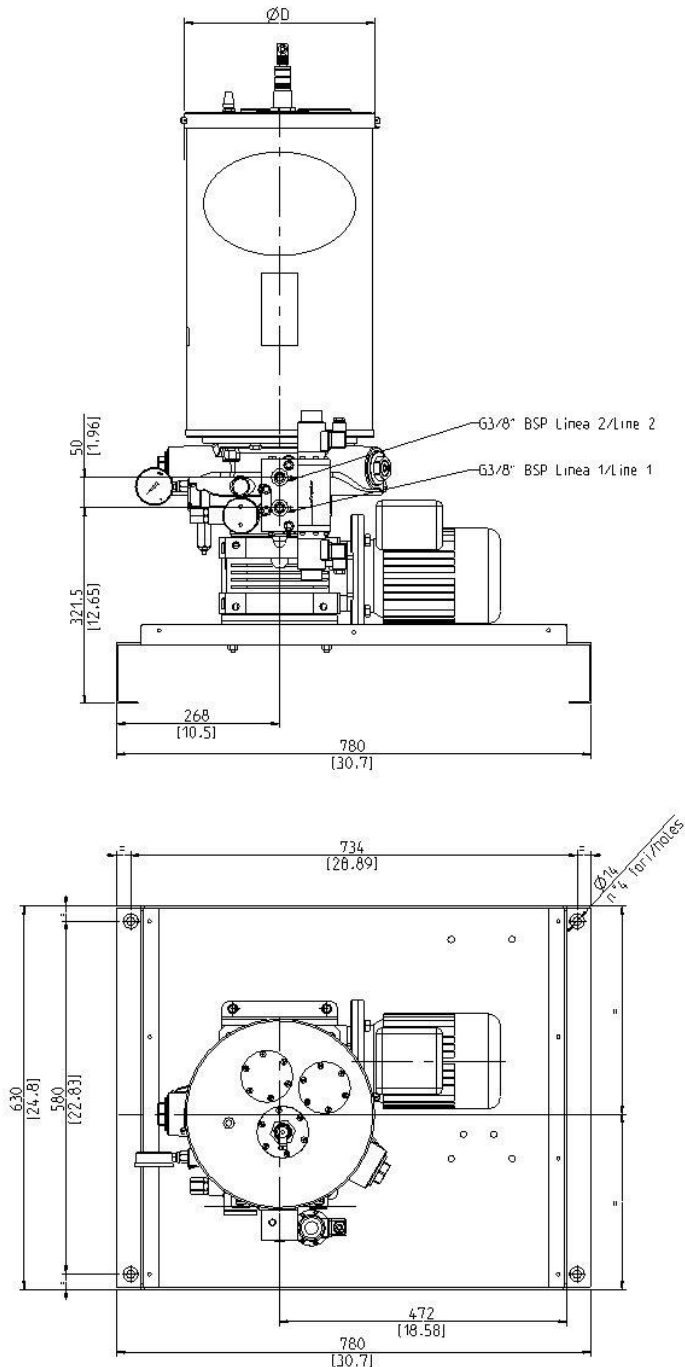

	30 Kg		100 Kg	
	mm	in	mm	in
A	533.5	21	983.5	38.7
B	1080	42.5	1530	60.2
C	980	38.58	1430	56.3
D	313	12.32	413	16.25



ORDERING INFORMATION

N.B. The part number of the pump is composed by 11 numbers.

				Standard			Optional				
				Data	4°	5°/6°	7°	8°	9°	10°	11°
<b>PUMP</b>				245	0	00	0	0	0	0	0
<b>DESCRIPTION</b>				<b>Part No. CODE</b>							
Reservoir	-			0							
	30kg			0295080 1							
	100kg			0295090 2							
Triphase electric motor	Motor not present			00							
	STANDARD IE3 230/400V 50Hz - 280/480V 60Hz			3301081 01							
	440 V 60 Hz			3301650 02							
	440 V 60 Hz with anti-condensation heater 110V AC			3301651 03							
	460 V 60 Hz			3301652 04							
	575 V 60 Hz			3301653 05							
	500 V 50 Hz			3301654 06							
	525 V 50 Hz			3301655 07							
	550 V 50 Hz			3301656 08							
	380 V 50/60 Hz			3301659 09							
	UL and CSA standard with IE3 230/ 400V 50 Hz - 280/480V 60Hz			3301528 50							
	440 V 60 Hz			3301670 51							
	460 V 60 Hz			3301671 52							
	460V 60Hz with anti-condensing heater 120V			3301556 53							
	575 V 60 Hz			3301672 54							
	500 V 50 Hz			3301673 55							
	550 V 50 Hz			3301674 56							
UL and NEMA standard 230/460V 60 Hz			On request 80								
Pneumatic motor				3301539 95							
Inverter NOT PRESENT				-							
4/3 Valve	24 V DC			0083550 1							
4/2 Electromagnetic inverter	24 V DC			0083560 2							
4/2 electro pneumatic inverter	24 V DC			0083580 3							
Hydraulic inverter				0086450 4							
<b>Optional</b>											
Minimum Level	Laser level standard 24V cc Out NO e NC (1 threshold)			0295131 0							
	Laser with 2 outlets digital configurable and 4÷20mA			0295130 1							
	Float Reed for oil 30kg			0295150+3130138 2							
	Float Reed for oil 100kg			0295160+3130138 3							
Maximum Level	Floating visual level			0295100 0							
	Laser 24V cc Out NO and NC (1 threshold)			0295131 1 (for 30kg and 100kg)							
Heating Band	Heating Band NOT PRESENT			-							
	100 kg Pump Heating Band			0295065 1							
	30 kg Pump Heating Band			0295066 2							
Pumping elements	The pump is equipped with 2 pumping elements with fixed flow rate			0296090 0							
	1 pumping element with fixed flow rate			0296090+0295049 +3190489-3190491 1							



OPTIONAL		CODES
Oil conversion	Min/max oil level float kit 30 Kg (66lb)	0295150
	Min/max oil level float kit 100 Kg (220lb)	0295160
	Filling cap with filter	3130138
Terminal Box bracket	Bracket for installing a terminal wiring box onto the base pallet	3044455
Terminal	Terminal box	0291655
Electrical control box Bracket	Bracket for installing a control box onto the base pallet	3044456
Metal pallet	Metal Pallet used as the base of the packaging and also for installation of the pump	0297150

SPARE PARTS		CODES
Motors	3Ph - 0,75 Kw IE3- 230Δ/400Y 50Hz 280Δ/480Y 60Hz	3301081
	3Ph UL e CSA - 0,75 Kw IE3- 230Δ/400Y 50H 280Δ/480Y 60Hz	3301528
Reducer i=40		3301608
Maximum mechanical level kit 30 and 100 Kg (grease)		0295100
Laser probe assembly 30÷100 Kg - 24V cc Out NO e NC (1 threshold)		0295131
Laser level kit 24V cc Out 4÷20mA/2 NO (4 thresholds) – 30 Kg		0295130
Laser level kit 24V cc Out 4÷20mA/2 NO (4 thresholds) – 100 Kg		
Grease loading filter		0295009
Stirring paddle filter		0297155
O-ring reservoir		3190485
Bypass		0234815
Pressure gauge 0 - 600 Bar		3292171
Pumping*		0296090C
Metallic pallet		0297150

**\*Attention:**

for pump with pumping element marked "A" the order code is 0296090C

for pump with pumping element without marking, the order code is 0296080C