

"FDH" Series Compact Finger Slides

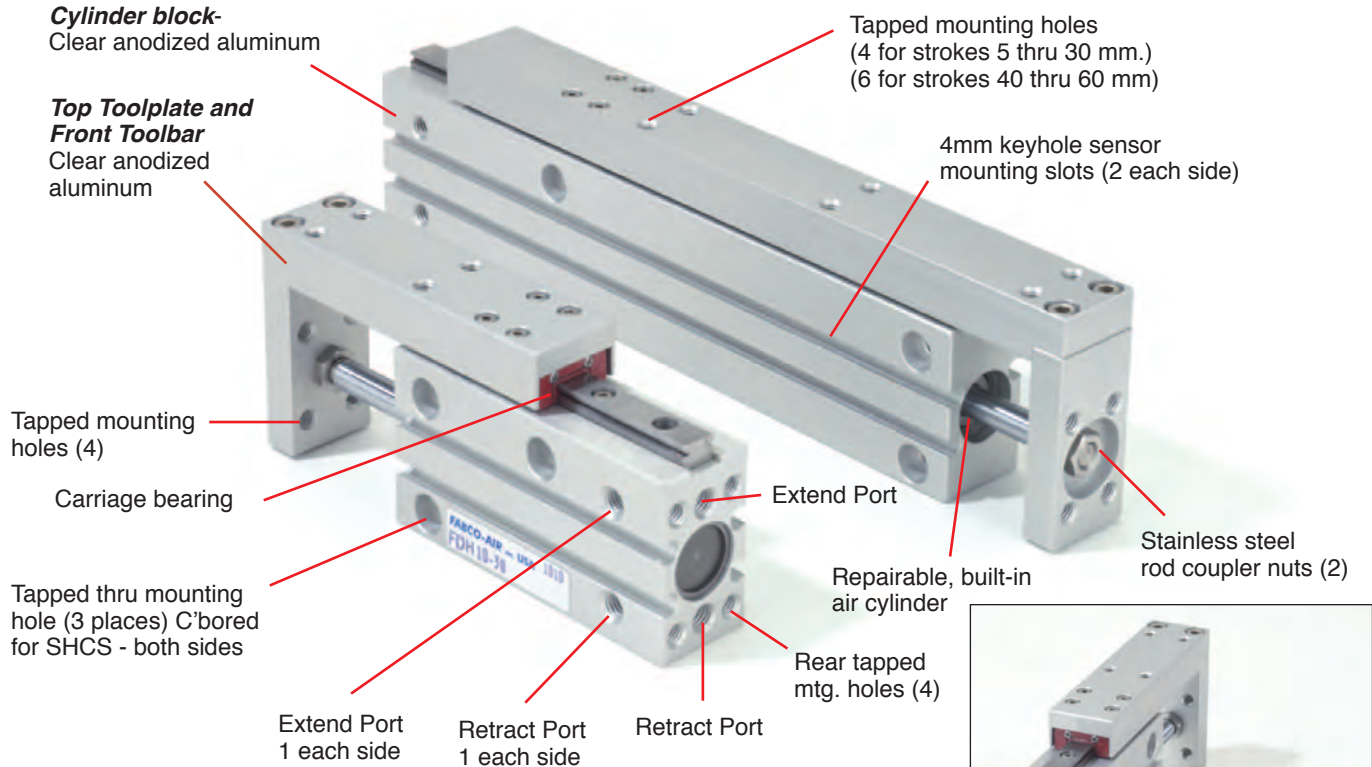

Available in 3 Bores
10, 16 & 20 mm

Standard Strokes
5, 10, 15, 20, 25,
30, 40, 50, 60 mm

Magnetic piston is
standard feature for
position sensing



Now get directly interchangeable, universal mount, compact pneumatic slides!

Check list of *Competitive Advantages* of "FDH" Series Finger Slides

- ✓ Longer strokes for all models.
- ✓ New round profile sensors feature surge suppression, polarity protection, LED indicator, and extremely fast switching speeds.
- ✓ Rubber bumpers provide cushioned stop.

Check list of *Standard Features*

- ✓ Four 4mm keyhole sensor mounting slots, two on each side.
- ✓ Clear anodized toolbar and toolplate.
- ✓ Stainless steel coupler nuts.

Versatile load attachment

- ✓ Tapped holes on top toolplate:
4 on strokes 5 thru 30mm.
6 on strokes 40 thru 60 mm.
- ✓ Tapped holes on front toolbar (4).

Easy, convenient slide mounting

- ✓ Side thru holes with C'bored in body.
- ✓ Side tapped mounting holes.
- ✓ Bottom tapped mounting holes.
- ✓ Rear tapped mounting holes.
- ✓ Toolbars are slightly narrower than body, allowing side mounting with clearance between toolbar and mounting surface.
- ✓ Ports accessed on either side and rear.

Specifications and prices subject to change without notice or incurring obligation

FABCO-AIR "FDH" Series Finger Slides

How to Order

Model Number Code		
FDH	10	x 60
Series	Bore	Stroke

- 1) Specify "FDH"
- 2) Specify the bore
- 3) Specify the stroke

Bore Size (mm)	Stroke Lengths (mm) / List Prices									Seal Kits / Prices	
	05	10	15	20	25	30	40	50	60	Part No.	Price
10	\$186.70	\$192.50	\$196.90	\$201.30	\$207.10	\$211.45	\$221.70	\$231.90	\$242.15	FDH10-SK	\$6.30
16	215.90	223.15	229.00	234.85	240.65	245.00	256.65	268.40	280.05	FDH16-SK	2.80
20	245.00	252.30	258.15	263.95	271.25	278.55	291.70	304.80	319.40	FDH20-SK	3.35

Note: Order sensors separately from page 3.

Specifications

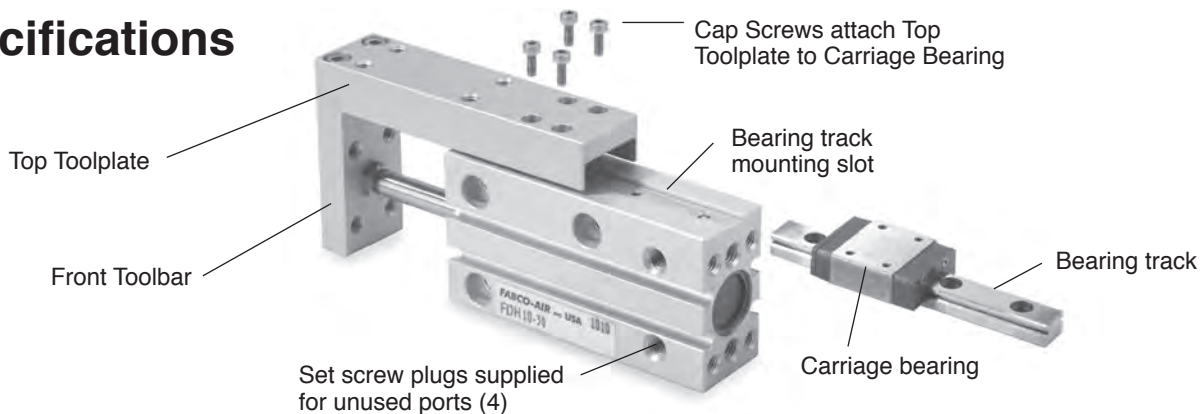

Specifications			
Bore Size (mm)	10	16	20
Bearing Track Width (mm)	7	9	12
Minimum Operating Pressure	10 psi 0.70 bar	10 psi 0.70 bar	10 psi 0.70 bar
Maximum Operating Pressure	140 psi 9.6 bar	140 psi 9.6 bar	140 psi 9.6 bar
Temperature Range	-10°C to 70°C (14°F to 158°F)		
Max. Recommended Speed	500 mm/sec. dependent on load values shown on pages 6 & 7		
Lubrication	Cylinder & Bearing: Factory Pre-lubed / Regular Lubrication Recommended		
Cushion	Rubber Bumpers both ends		
Cylinder seals	Buna-N		

Theoretical Force Output Guide			
Bore (Piston) Diameter (mm)	10	16	20
Rod Diameter (mm)	4	6	8
Extend Piston Area (in ²)	0.12	0.31	0.49
Retract Piston Area (in ²)	0.10	0.26	0.41

Weights (lbs)									
Model	Stroke (mm)								
	05	10	15	20	25	30	40	50	60
FDH10	0.26	0.28	0.31	0.33	0.36	0.37	0.42	0.47	0.52
FDH16	0.48	0.50	0.54	0.57	0.62	0.64	0.71	0.79	0.85
FDH20	0.96	1.00	1.07	1.11	1.19	1.23	1.32	1.45	1.54

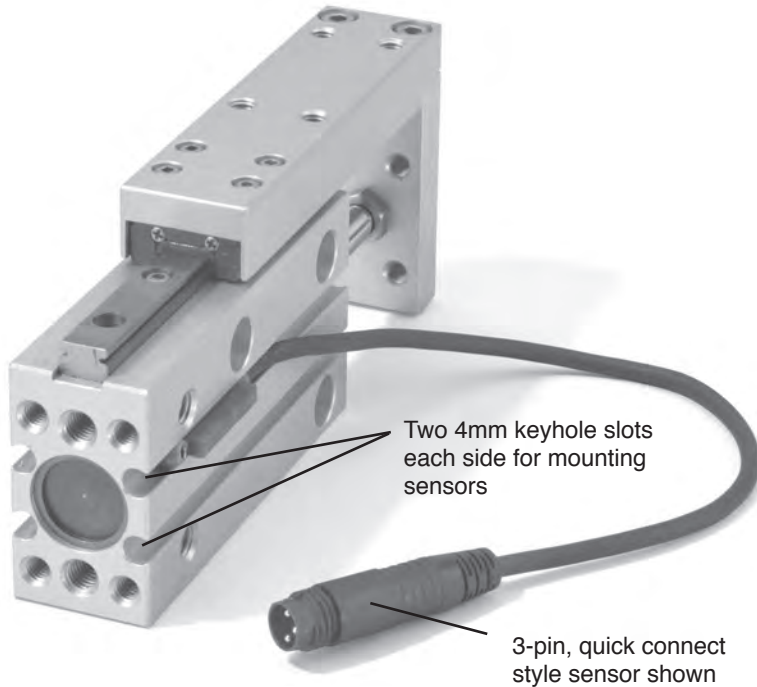

Round Profile Sensors

feature surge suppression, polarity protection, LED indicator, and extremely fast switching speeds. They slide into mating 4mm keyhole slots on either side of the cylinder block and are easily positioned and locked in place with a set screw. They are offered in two styles: a quick connect style with a 6 inch pigtail and male connector, or a prewired style with a 9 foot lead.

Female Cordsets

are available in 3 pin configurations in 1, 2 and 5 meter lengths.

Order sensors and cordsets separately from the tables below.

Sensor Dimensions (mm unless noted)

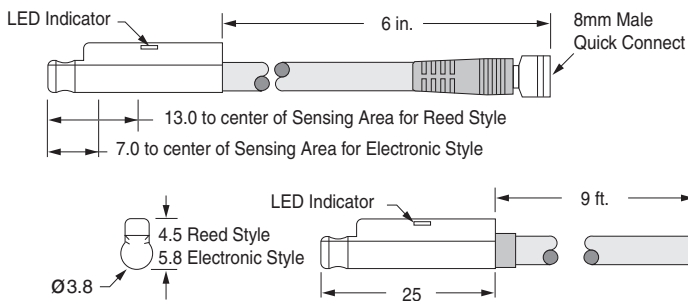

Prewired sensor shown with 9 ft. lead



3 pin cordset shown with sensor pigtail

All sensors feature surge suppression, polarity protection, LED indicator, and extremely fast switching speeds.

8mm Female Cordsets for Quick Connect Sensors		
Cordset Description	Part No.	List Prices
1 meter, 3-pin	CFC-1M	-
2 meters, 3-Pin	CFC-2M	-
5 meters, 3-Pin	CFC-5M	-

Magnetic Sensors – Electrical Characteristics							Part Numbers and Prices			
Sensor Type	Function	Switching Voltage	Switching Current	Switching Power	Switching Speed	Voltage Drop	Prewired 9 ft. Part No.	Price	Quick Connect Part No.	Price
Reed Switch for PLC's w/LED (current limiting)	SPST Normally Open	5-120V AC/DC 50/60 Hz	0.04 Amp max 0.005 Amp min.	4 Watts max.	0.5 ms operate 0.1 ms release	2.5 Volts	9C49-000-002	-	9C49-000-302 Requires 3 pin cordset	-
Electronic LED and Sourcing	PNP Normally Open	6-30 VDC	0.2 Amp max.	6 Watts max.	1.5µs operate 0.5µs release	1.5 Volts	9C49-000-031	-	9C49-000-331 Requires 3 pin cordset	-
Electronic LED and Sinking	NPN Normally Open	6-30 VDC	0.2 Amp max.	6 Watts max.	1.5µs operate 0.5µs release	1.5 Volts	9C49-000-032	-	9C49-000-332 Requires 3 pin cordset	-

FABCO-AIR "FDH" Series Finger Slides

Construction

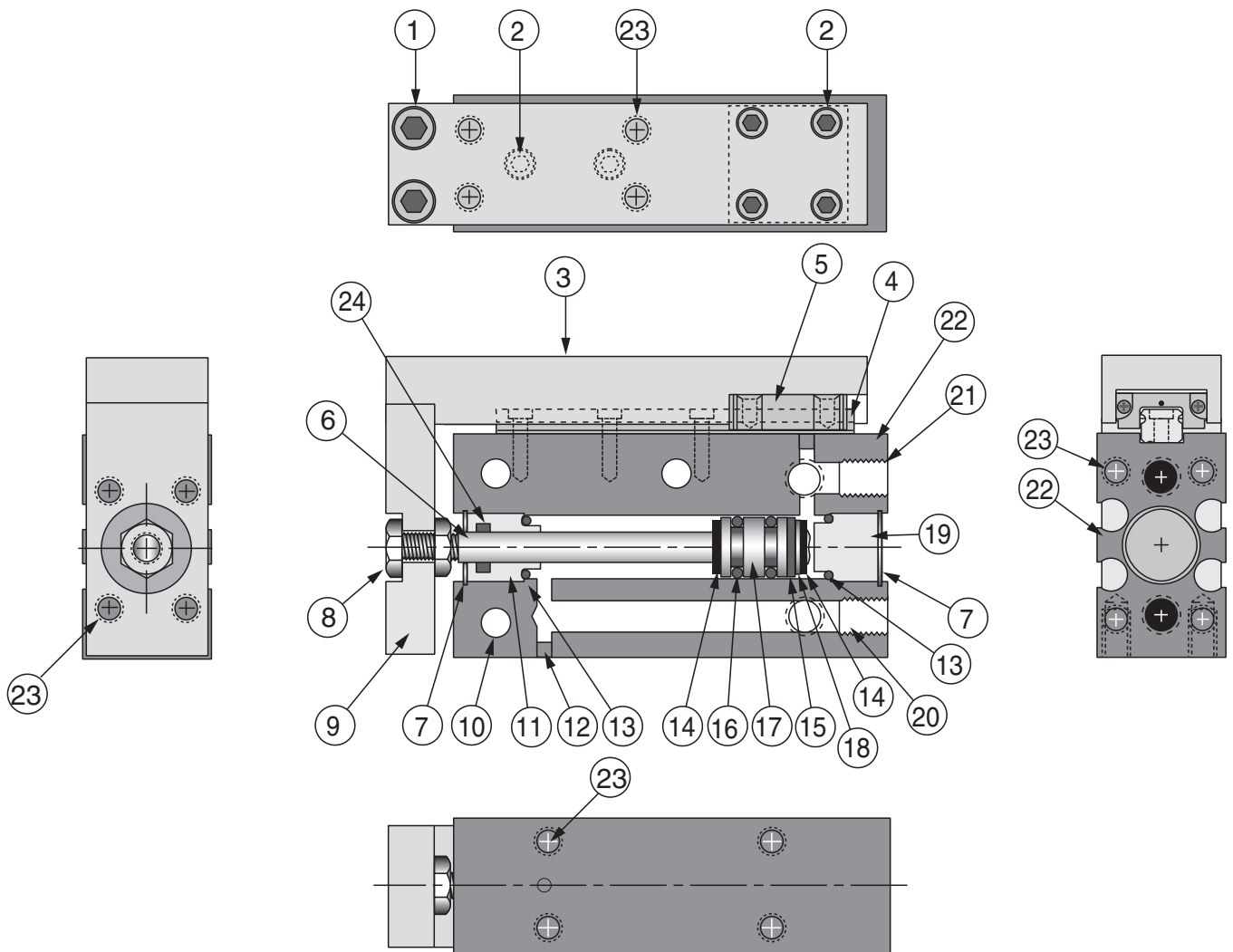

Quick Reference to Components

No.	Description	Material	No.	Description	Material
1	Hex socket head cap screw	stainless steel	13	Cap seal	Buna-N
2	Hex socket head cap screw	stainless steel	14	Cushion/Bumper	Urethane
3	Top toolplate	anodized aluminum	15	Magnet for position sensors	plated neodymium
4	Bearing track	precision bearing guide element	16	Piston seal	Buna-N
5	Carriage bearing	recirculating ball bearing	17	Piston	aluminum
6	Piston rod	stainless steel	18	Magnet retainer	
7	Retainer ring	plated carbon spring steel	19	End cap	anodized aluminum
8	Rod coupler nuts	stainless steel	20	Retract port	
9	Front toolbar	anodized aluminum	21	Extend port	
10	Tapped mounting holes	w/counterbore for thru bolt	22	Cylinder block	anodized aluminum
11	Rod end cap	anodized aluminum	23	Tapped mounting holes	
12	Plug	stainless steel	24	Rod seal	Buna-N

Construction and Dimensions

5 thru 60 mm strokes

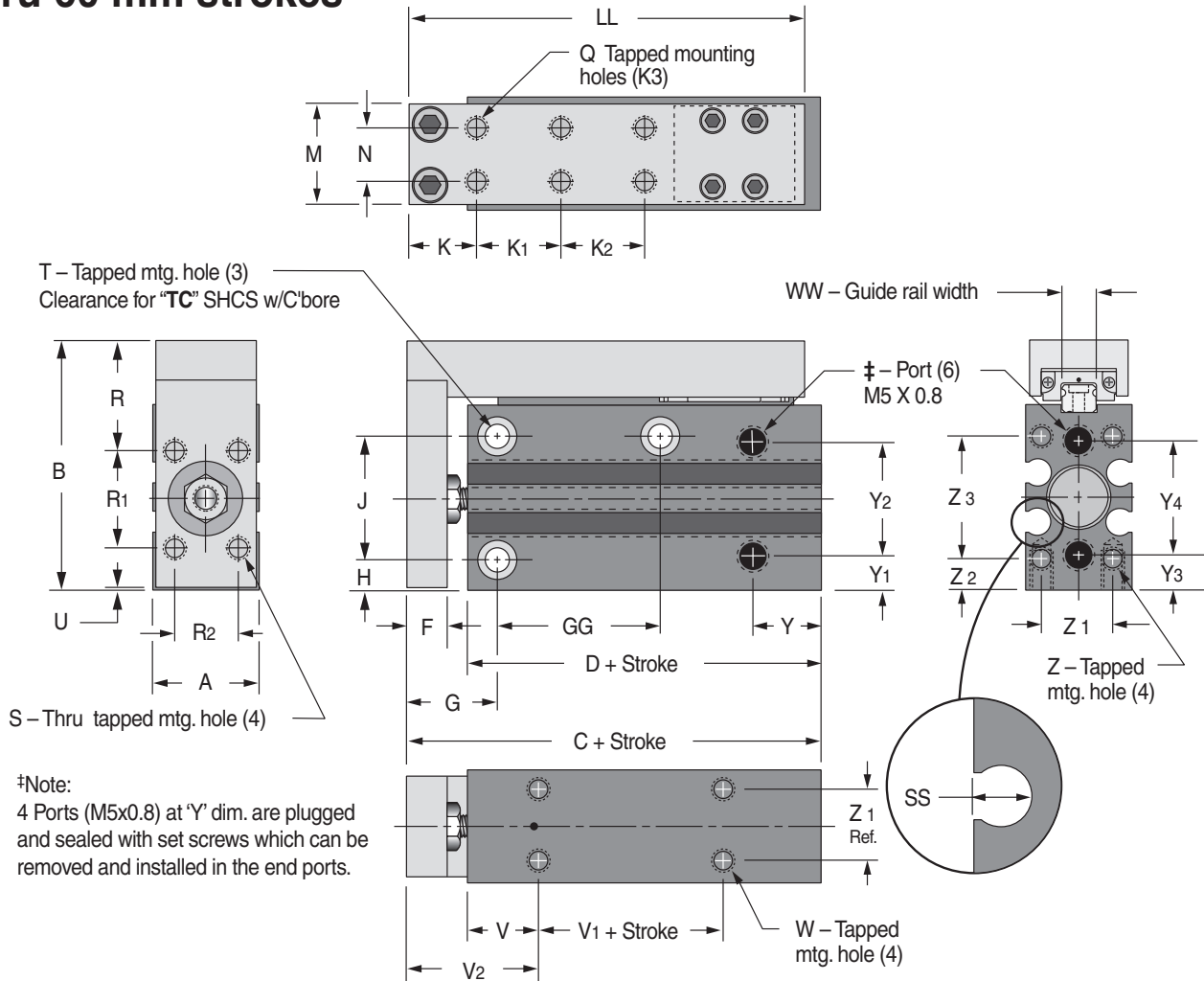

Bore	A	B	C	D	F	G	H	J	K	M	N	Q by depth	R	R1	R2	S	SS
10mm	20	47.0	46.5	35.0	7.5	16.5	5.0	23	11	19	11.0	M4 x 0.7 - 7	21.5	18	11	M4 x 0.7	3.8
16mm	25	53.5	56.0	42.0	10.0	19.0	5.5	27	14	24	16.0	M4 x 0.7 - 7	21.5	26	16	M4 x 0.7	4.6
20mm	32	64.5	68.0	52.5	11.0	21.5	6.0	34	14	31	20.0	M5 x 0.8 - 9.5	24.5	34	20	M5 x 0.8	5.9

Bore	T	TC	U	V	V1	V2	W by depth	WW	Y	Y1	Y2	Y3	Y4	Z by depth	Z1	Z2	Z3
10mm	M5 x 0.8	M4	0.5	12.0	5.0	23.5	M4 x 0.7 - 6	7.0	12.5	6.5	20	7.0	19	M4 x 0.7 - 6	13.0	5.0	23
16mm	M5 X 0.8	M4	1.0	12.0	10.0	26.0	M4 x 0.7 - 6	9.0	12.5	6.5	25	6.5	25	M4 x 0.7 - 6	17.0	5.5	27
20mm	M6 X 1.0	M5	1.0	15.0	10.0	30.5	M5 x 0.8 - 8	12.0	15.0	7.5	31	7.5	31	M5 x 0.8 - 5	20.0	6.0	34

Stroke	10 mm Bore					16 mm Bore					20 mm Bore				
	GG	K1	K2	K3	LL	GG	K1	K2	K3	LL	GG	K1	K2	K3	LL
5	14	10	-	4	49	20	10	-	4	58	20	10	-	4	64
10	14	10	-	4	49	20	10	-	4	58	20	10	-	4	64
15	24	20	-	4	59	30	20	-	4	68	25	20	-	4	74
20	24	20	-	4	59	30	20	-	4	68	25	20	-	4	74
25	30	30	-	4	69	40	30	-	4	78	40	30	-	4	84
30	30	30	-	4	69	40	30	-	4	78	40	30	-	4	84
40	45	20	20	6	79	50	20	20	6	88	50	20	20	6	94
50	55	25	25	6	89	60	25	25	6	98	70	25	25	6	104
60	60	30	30	6	99	60	30	30	6	108	70	30	30	6	114

FABCO-AIR "FDH" Series Finger Slides

Horizontal Mounting

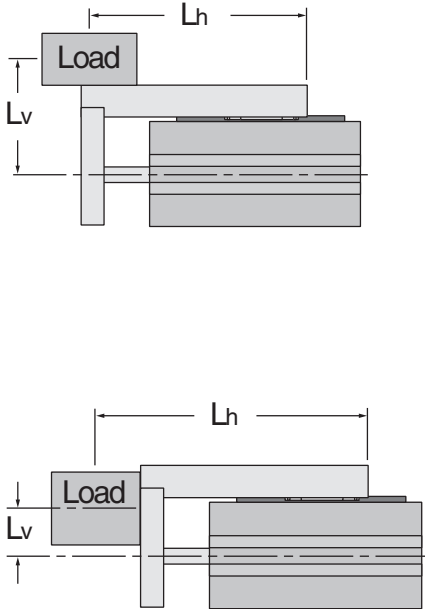

Maximum Safe Load in kg for 60mm stroke and shorter													
Bore	Speed mm/sec	Distance Lh in mm	Lv Distance in mm										
			0	10	20	30	40	50	60	70	80	90	100
10	100	50	1.70	1.30	0.91	0.78	0.65	0.56	0.50	0.43	0.40	0.36	0.33
		100	0.81	0.70	0.62	0.55	0.48	0.43	0.40	0.36	0.33	0.31	0.30
		200	0.42	0.39	0.35	0.32	0.30	0.28	0.26	0.25	0.23	0.22	0.20
	300	50	0.55	0.40	0.23	0.17	0.13	0.11	0.087	0.077	0.070	0.064	0.057
		100	0.55	0.31	0.21	0.16	0.11	0.09	0.078	0.068	0.059	0.052	0.050
		200	0.40	0.24	0.17	0.13	0.10	0.085	0.071	0.065	0.058	0.050	0.048
	500	50	0.20	0.16	0.09	0.06	0.048	0.039	0.032	0.028	0.024	0.021	0.020
		100	0.20	0.15	0.08	0.06	0.044	0.036	0.030	0.027	0.024	0.021	0.019
		200	0.17	0.13	0.07	0.05	0.037	0.031	0.026	0.023	0.020	0.018	0.015
16	100	50	3.20	2.30	1.90	1.50	1.30	1.10	0.97	0.90	0.80	0.73	0.67
		100	1.70	1.50	1.30	1.10	0.92	0.83	0.75	0.68	0.62	0.59	0.57
		200	0.95	0.88	0.80	0.76	0.70	0.67	0.61	0.59	0.54	0.50	0.49
	300	50	1.00	0.78	0.45	0.30	0.24	0.19	0.17	0.15	0.13	0.12	0.10
		100	1.00	0.61	0.39	0.28	0.22	0.18	0.17	0.14	0.12	0.11	0.10
		200	1.00	0.60	0.39	0.28	0.22	0.18	0.17	0.14	0.12	0.11	0.10
	500	50	0.40	0.30	0.18	0.12	0.09	0.08	0.062	0.051	0.046	0.040	0.038
		100	0.40	0.30	0.18	0.12	0.09	0.08	0.062	0.051	0.046	0.040	0.038
		200	0.34	0.25	0.15	0.10	0.076	0.068	0.052	0.043	0.039	0.034	0.032
20	100	50	5.30	3.80	3.00	2.50	2.20	1.90	1.70	1.50	1.40	1.20	1.10
		100	2.80	2.40	2.10	1.80	1.70	1.50	1.30	1.20	1.10	0.99	0.95
		200	1.40	1.30	1.20	1.10	0.98	0.91	0.89	0.81	0.78	0.72	0.70
	300	50	2.10	1.30	0.80	0.54	0.41	0.33	0.28	0.24	0.21	0.20	0.18
		100	2.10	1.30	0.72	0.50	0.39	0.31	0.27	0.23	0.21	0.19	0.18
		200	1.50	0.80	0.59	0.45	0.36	0.30	0.26	0.22	0.19	0.18	0.17
	500	50	0.73	0.59	0.32	0.20	0.17	0.14	0.11	0.092	0.086	0.078	0.070
		100	0.73	0.42	0.27	0.19	0.15	0.12	0.10	0.087	0.078	0.069	0.060
		200	0.62	0.36	0.23	0.16	0.13	0.10	0.085	0.074	0.066	0.059	0.051

Vertical Mounting

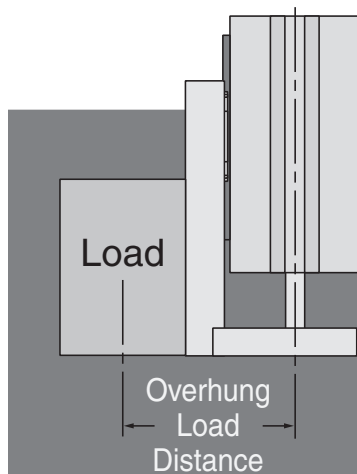

Maximum Safe Load in kg for 60mm stroke and shorter												
Bore	Speed mm/sec	Overhung Load Distance in mm										
		0	10	20	30	40	50	60	70	80	90	100
10	100	2.80	2.20	1.30	0.87	0.69	0.59	0.48	0.39	0.35	0.31	0.29
	300	0.58	0.50	0.25	0.16	0.11	0.087	0.077	0.070	0.063	0.058	0.053
	500	0.21	0.19	0.09	0.06	0.047	0.037	0.032	0.028	0.025	0.022	0.020
16	100	7.40	4.20	2.10	1.60	1.25	1.00	0.87	0.77	0.69	0.64	0.58
	300	1.10	0.93	0.46	0.32	0.22	0.19	0.16	0.13	0.11	0.094	0.090
	500	0.40	0.36	0.18	0.13	0.09	0.073	0.060	0.051	0.046	0.042	0.037
20	100	10.10	7.00	3.60	2.40	2.00	1.70	1.50	1.30	1.10	1.00	0.95
	300	2.20	1.70	0.85	0.55	0.42	0.32	0.28	0.23	0.21	0.18	0.17
	500	0.80	0.60	0.31	0.20	0.16	0.13	0.11	0.088	0.080	0.070	0.065

Pitch, Yaw, Roll Moments

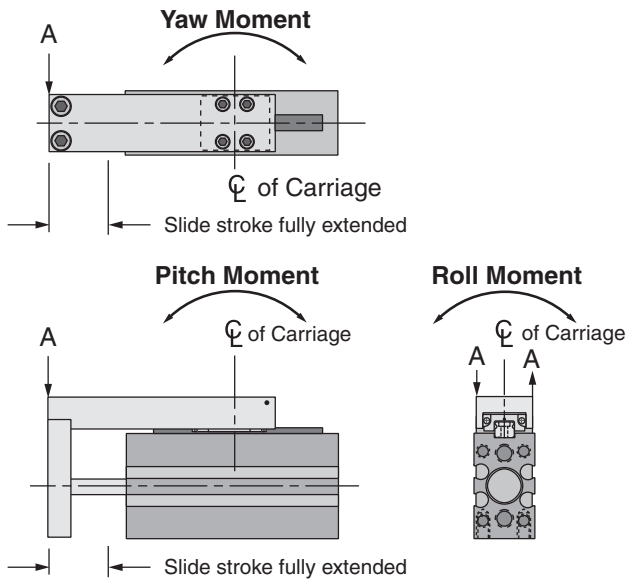

ft-lbs = N-m x 0.738

Safe Dynamic Carriage Loading			
Bore / Stroke Range	Pitch Moment (N-m)	Yaw Moment (N-m)	Roll Moment (N-m)
10 (5-60mm strokes)	0.96	0.82	1.37
16 (5-60mm strokes)	1.88	1.59	2.75
20 (5-60mm strokes)	3.14	2.75	5.49

Approximate deflection of finger slide at A as a result of moment loads

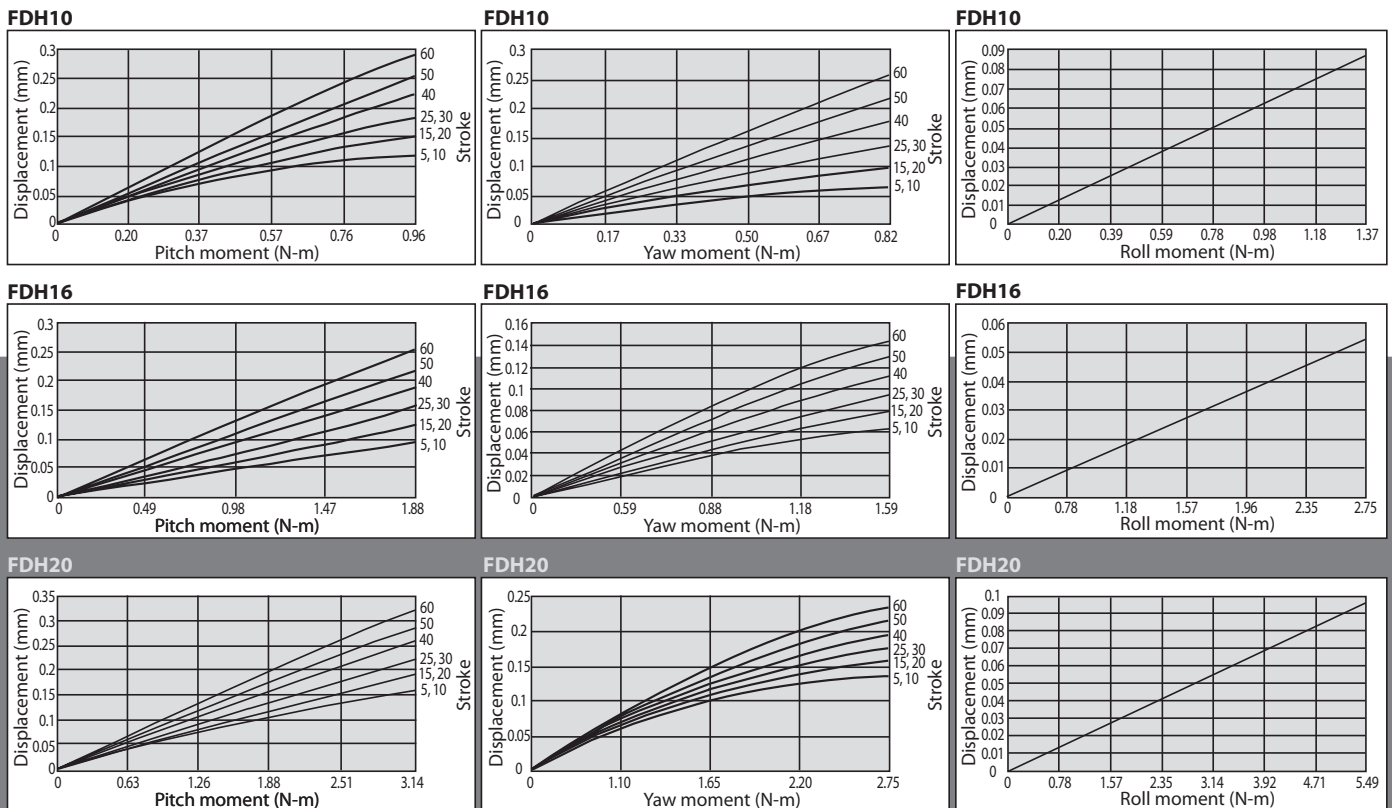

Check out these new product lines today !



Cylinders, Valves and Accessories
Catalog # CV9



Pancake® II Air Cylinders
Catalog Pan2-2



Square Pancake® II Air Cylinders
Catalog # SqPan2



ISO 6431 Cylinders
Catalog # FAQR-09



Twin Rod, Non-Rotating Air Cylinders - Catalog # FDF-09 and Catalog # FDXS-09



High Closing Force Angular Grippers
Catalog # FKHC-10



Multi-Power® Air Presses
Catalog # FP16



Linear Slides - 6 Families
Catalog # LS-03



Pneumatic Grippers, Parallel Jaw and Angular Motion - Catalog # GR-8



ISO 6432 Cylinders
Catalog # FAE-09

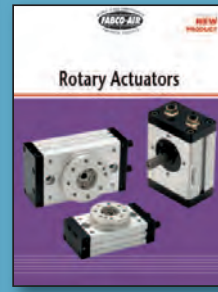

Rotary Actuators, Pneumatic
Catalog # FRA.C-09

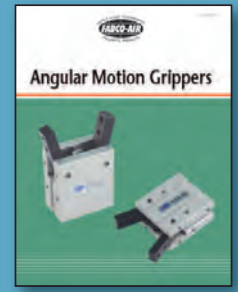

Angular Grippers
Catalog # FKA-09



NFPA Interchangeable Air Cylinders - Catalog # NF-6

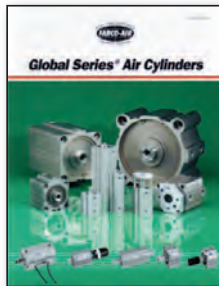

Global Series™ Metric Air Cylinders - Catalog # GC-15



Stopper Cylinders
Catalog # ST-SC



Toggle Type Angular Grippers - Catalog # FKHT-10

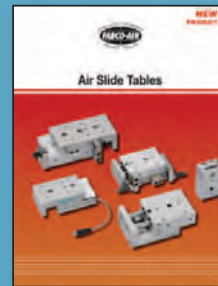

Air Table Slides
Catalog # FGXS-10



Wide & Narrow Parallel Grippers - Catalogs # FKHZ-10 & FKHQ-10



Modular Air Preparation System - FRLs
Catalog # FRL-06

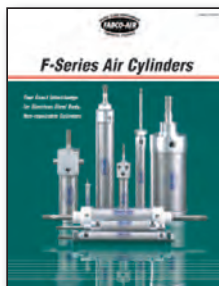

Stainless Steel Body Air Cylinders
Catalog # SSB-03

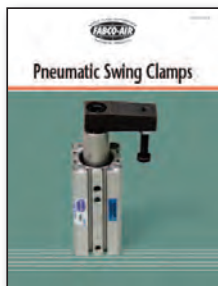

Swing Clamps
Catalog # SC-DB04

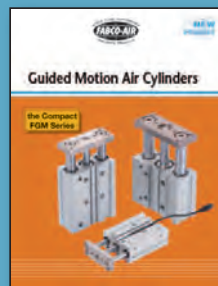

Guided Motion Air Cylinders
Catalog # FGM-10



Pneumatic & Hydraulic Swing Clamps
Catalog # FML.H



Wide Opening Parallel Grippers
Catalog # FKHL-10