

**Product Information**

**Flow Switch FX**



- Adjusted switching value
- Integrated filter
- High switching power
- Optional flow limiter in the outlet piece

**Characteristics**

Mechanical flow switch, for fluid media, with magnetic triggering of a reed switch. Plastic housing with integrated filter.

**Technical data**

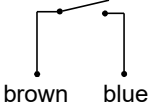
<b>Switch</b>	reed switch	
<b>Nominal width</b>	DN 15	
<b>Process connection</b>	male thread G 1/2 A (note: For plastic parts it is not possible to guarantee trueness of calibration)	
<b>Switching range</b>	0.4..12 l/min	for details see table "Ranges"
<b>Pressure loss</b>	0.75..1.1 bar at Q <sub>max.</sub>	
<b>Q<sub>max.</sub></b>	12 l/min	
<b>Tolerance</b>	±15 % of full scale value	
<b>Pressure resistance</b>	PN 10 bar	
<b>Media temperature</b>	-20..+70 °C (80 °C at 6 bar)	
<b>Ambient temperature</b>	-20..+70 °C	
<b>Media</b>	water	
<b>Wiring</b>	normally open ( n.o.) No. 0.372	
<b>Switching voltage</b>	max. 230 V AC	
<b>Switching current</b>	max. 1 A	
<b>Switching capacity</b>	max. 50 VA	
<b>Protection class</b>	2 - safety insulation	
<b>Ingress protection</b>	IP 65	
<b>Electrical connection</b>	cable 0.5 m	
<b>Materials medium-contact</b>	POM GV, CW614N, CuSn8, hard ferrite, NBR, Nylon type FXF with additional spring 1.4310	
<b>Non-medium-contact materials</b>	PVC	
<b>Weight</b>	without spring 0.14 kg with spring 0.15 kg	
<b>Installation location</b>	Standard: All mounting positions except entry above are possible, the mounting position has influence on the switching point.	
<b>Filter</b>	25 µm	

**Ranges**

Details in the table correspond to horizontal inwards flow with decreasing flow rate.

G	Spring	Switching value l/min H <sub>2</sub> O Choose between	Q <sub>max.</sub> recommended	Pressure loss bar at Q <sub>max.</sub> H <sub>2</sub> O	Type
G 1/2 A	no	0.4 - 5	12	0.75	FX-015AP
	yes	2.0 - 12	15	1.10	FXF-015AP

Special ranges are available.

**Dimensions**

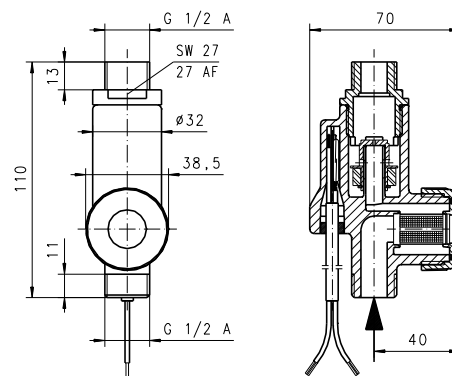

**Handling and operation**

- Include straight calming section of 5 x DN in inlet and outlet
- It must be ensured that the values given for voltage, current, and power are not exceeded.
- When switch on, a load must be connected in series.
- The electrical details apply to ohmic loads. Capacitive, inductive and lamp loads must be operated using a protective circuit.

**Product Information**

**FX-015AP**

**Ordering code**

1. 2. 3. 4.  
FX

<b>1. Spring-supported</b>	
-	without spring support
F-	with spring support
<b>2. Nominal width</b>	
015	DN 15 - G 1/2 A
<b>3. Process connection</b>	
A	male thread
<b>4. Connection material</b>	
P	POM

**Ordering information**

- Specify direction of flow, medium, and switching value.
- For gases, state pressure (relative or absolute), temperature and medium (e.g. air) (request switching value).
- Integrated flow limiter

**Options**

**Integrated flow limiter**

**Characteristics**

Mechanical flow limiter for fluid media. From a pre-pressure greater than 2 bar, the flow rate is controlled to the desired volume flow.

Flow value% of controlled value

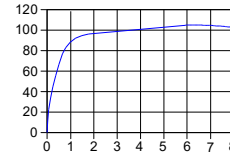

**Technical data**

<b>Controlled values</b>	3 l/min	5 l/min	6 l/min
	8 l/min	10 l/min	12 l/min
<b>Differential pressure</b>	2..10 bar		
<b>Tolerance</b>	±15 %		
<b>Medium temperature</b>	0..65 °C		
<b>Ambient temperature</b>	0..65 °C		
<b>Medium</b>	water		
<b>Materials</b>	POM, NBR		
<b>Weight</b>	0.05 kg additionally		