

JUMO GmbH & Co. KG
 Delivery address: Mackenrodtstraße 14
 36039 Fulda, Germany
 Postal address: 36035 Fulda, Germany
 Phone: +49 661 6003-0
 Fax: +49 661 6003-607
 E-mail: mail@jumo.net
 Internet: www.jumo.net

JUMO Instrument Co. Ltd.
 JUMO House
 Temple Bank, Riverway
 Harlow, Essex CM20 2DY, UK
 Phone: +44 1279 635533
 Fax: +44 1279 635262
 E-mail: sales@jumo.co.uk
 Internet: www.jumo.co.uk

JUMO Process Control, Inc.
 6733 Myers Road
 East Syracuse, NY 13057, USA
 Phone: 315-437-5866
 1-800-554-5866
 Fax: 315-437-5860
 E-mail: info.us@jumo.net
 Internet: www.jumousa.com



JUMO IMAGO F3000

Process controllers

for the meat processing industry

Brief description

These process controllers are built to a modular design, and are suitable for the control and regulation of cooking, smoking and climate-control installations, and all associated equipment such as smoke generators, catalyzers etc. They are available in both upright (portrait) and horizontal (landscape) formats.

The unit has a 5" color display capable of showing 27 colors. Templates for the user interface can be individually adjusted and laid out by the users themselves. Texts, process values, background diagrams and icons can be arranged as required. A status line indicates the last alarm that occurred. LED displays have also been included, so that the most important process variables are visible from a distance. Individual keys can be assigned to special functions and labelled accordingly.

The instrument can store up to 99 named profile programs of up to 99 segments. All the processes required in the system are defined in 99 process steps and then simply called up sequentially for the program entry. An optional Plug & Play memory is available that can store all the data from the instrument, thus enabling easy exchange of hardware without any problems caused by lost data. The "Teleservice" software makes it possible to carry out configuration from a remote location, via a modem and the telephone network, thus saving on-site service costs.

A communication interface for MODbus or Profibus-DP facilitates integrating the instrument into a network.

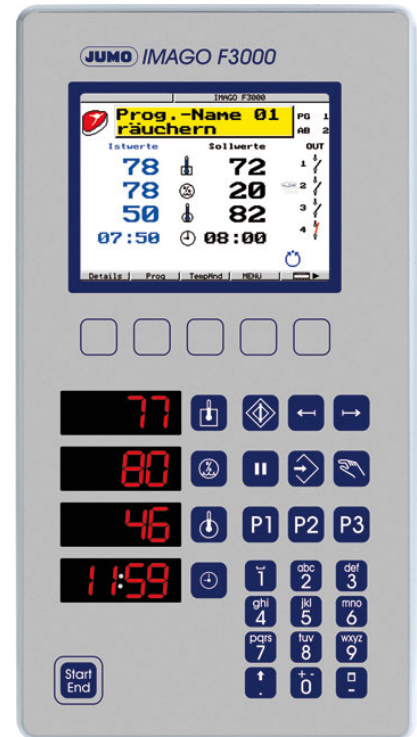

Block structure

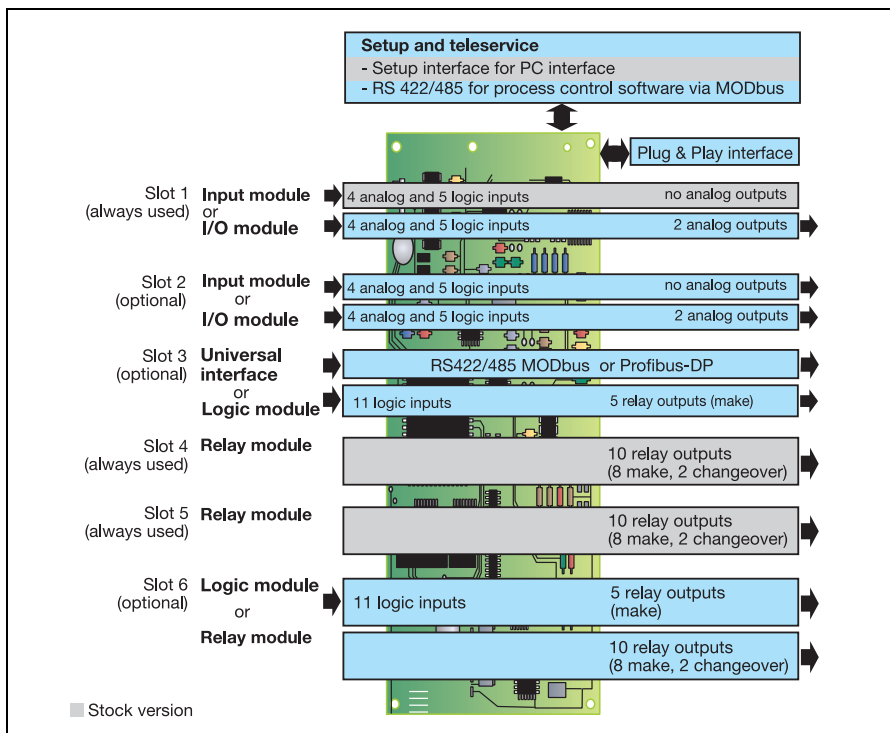

Type 700101/1...

Key features

- Two screen layout templates (masks) for automatic operation and one for the basic status, all freely editable
- 5" color display, 12mm LED displays for process values
- Plug & Play memory, to back up configuration data, transfer programs from one instrument to another, and to read in instrument software
- Configuration and parameter levels in English, German, French
- Math and logic functions
- Teleservice via modem
- Setup program for Windows 95/98/NT4.0/2000/ME/XP
- Program editor

Approvals/approval marks (see techn. data)



Display and control elements

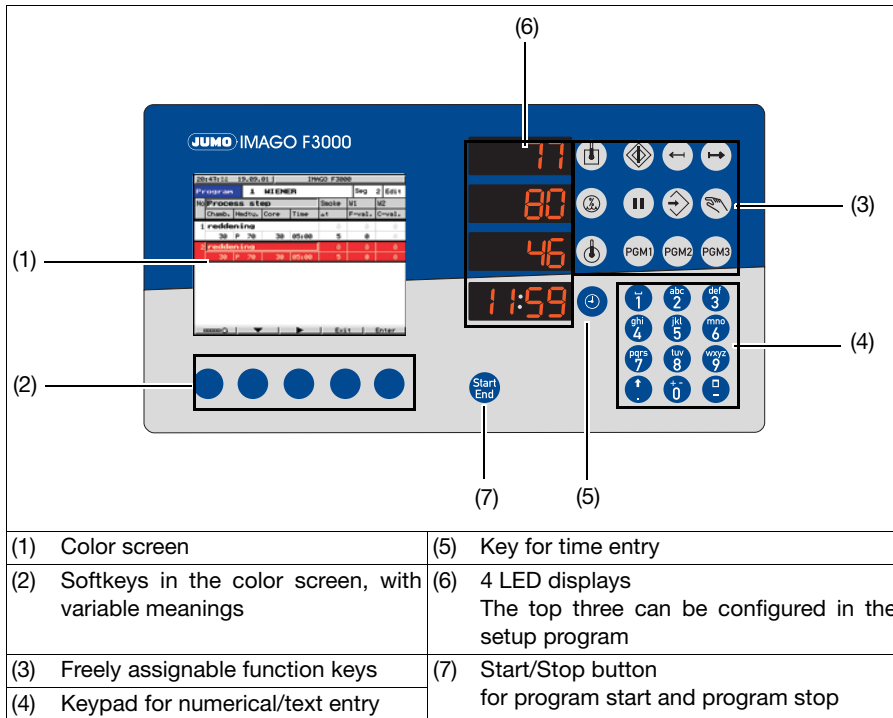

Programs

99 profile programs can be entered, stored, and changed at any time. They are made up of various process steps with the associated setpoint values. A program can have a maximum of 99 segments. A total of 3000 segments can be stored for all programs together. The programs are chosen from a list or selected by meaningful icons.



Segments

A segment consists of a process step, up to 9 setpoint values, and the segment time. Various conditions for moving to the next step control the segment sequence.

Process steps

A process step contains various pre-defined systems states for smoking, reddening etc., which are usually specified by the system manufacturer.

The user only has to select the process and enter the appropriate setpoints. Up to 99 process steps can be stored.

Step-on conditions

The system steps on to the next segments when...

- ... the segment time has elapsed
- ... the programmed core temperature has been reached
- ... the segment time has elapsed and/or the programmed core temperature has been reached.
- ... the programmed final F value has been reached.
- ... the programmed final C value has been reached.
- ... a logic input that was configured as a condition for stepping on has been activated.
- ... the programmed final F value and the programmed core temperature have been reached.

Cooking process

The process can be controlled by the delta cooking or F-value cooking methods.

Signal for end of program

This is provided by a relay output.

Operating functions

18 of the total of 36 operating outputs can have a switching response assigned. They can be configured for ON-advance, OFF-advance, ON-delay or OFF-delay with respect to the changeover point from one segment to another. A pulse/pause ratio can also be selected. All times can be set individually.

2 timers

After entering an operating time for the system, a counter runs and the system has to be enabled by a password. A second counter can, for instance, be used to monitor and signal cleaning intervals.

Math and logic functions

The math module makes it possible to include setpoints, output levels, analog input measurements and the like in a mathematical formula.

The logic module can be used to create a logical combination of such variables as logic inputs, limit comparators and operating outputs.

A maximum of 4 math functions and 8 logic combinations can be entered via the setup program, and the results of these functions can be delivered at the outputs or used internally.

All logic formulae are processed and become effective within 100ms.

Self-optimization

Standard features include self-optimization, making it possible for a user to adapt the controller to match the control loop without any knowledge of control systems engineering.

This feature tests and evaluates the response of the control loop to specific changes in the control input parameters. The control parameters Xp, Tn, Tv and Cy are calculated.

PC programs

■ Setup program

The setup program for configuring the instrument can be installed in English, German or French. A PC can be used to create sets of data, edit them, transfer them to the process controls, or read them out from the instrument. The sets of data are stored and managed. 3 process layouts can be freely configured.

■ Teleservice

- Remote configuration and diagnosis of the system via modem
- Establish a connection through the setup program, dialling by:
 - a) direct-dialling through the setup, or
 - b) callback
- Display system status, such as operating modes, logic inputs and outputs, alarms and system information.

■ Process steps

Process steps are defined through the setup program and transferred to the instrument. The program editor is used to compile the programs.

RS422/RS485 interface (option)

The serial interface is used for communication with higher-level (supervisory) systems, and includes electrical isolation. The transmission protocols used are MODbus and Profibus.

Plug & Play memory (option)

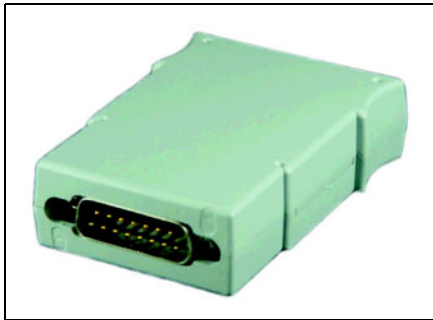

This is plugged into the back of the instrument, and can store all the instrument data, or a selection:

- parameter and configuration data
- process steps
- user programs
- instrument software version

Practical applications are for:



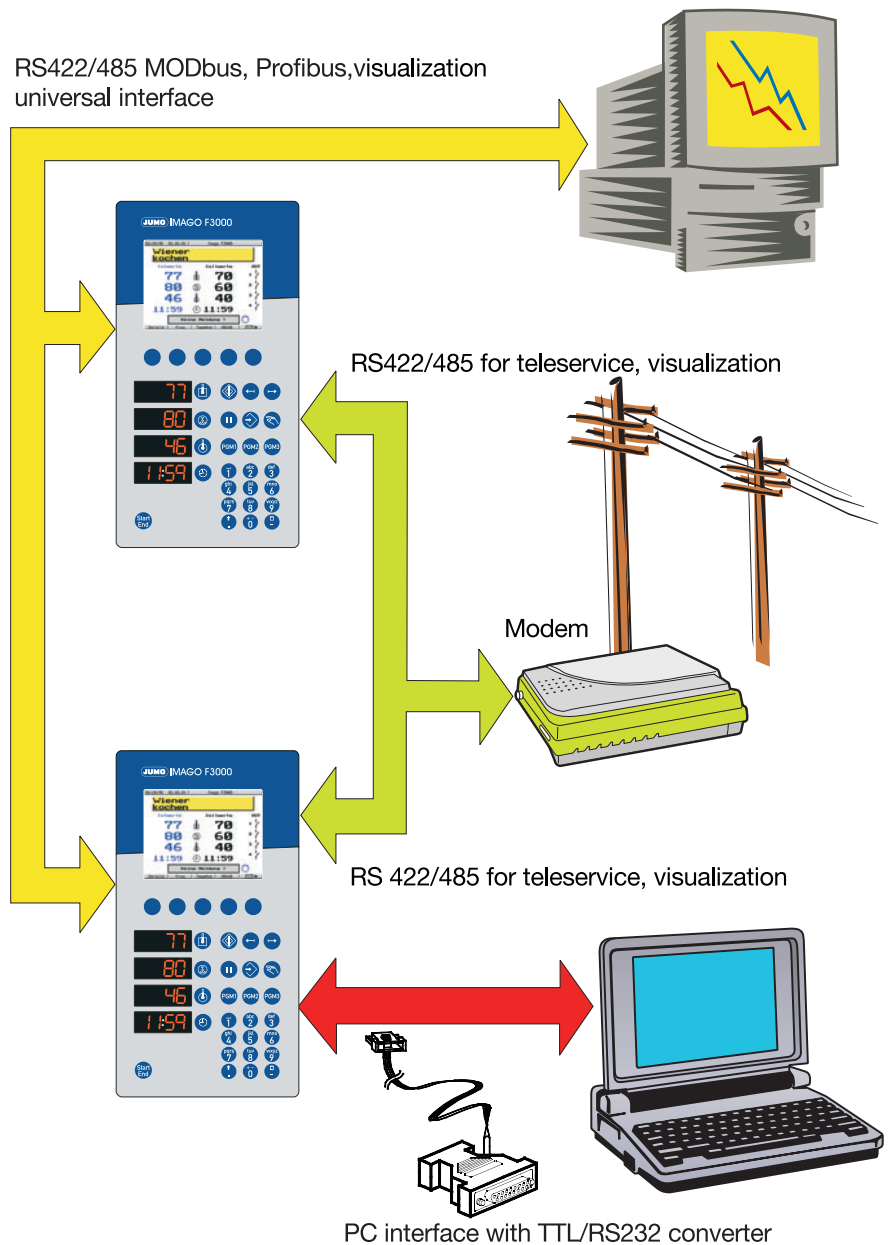

- simple configuration after a hardware replacement
- reading in new setup data from the system manufacturer
- copying user programs
- reading in new applications programs from the manufacturer
- reading in new instrument software

Interfaces for teleservice, setup and visualization

RS422/485 MODbus, Profibus, visualization universal interface

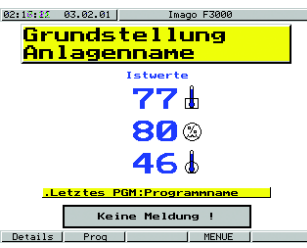
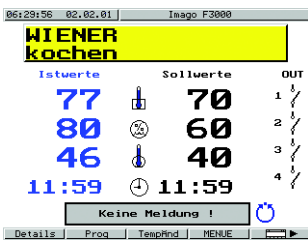
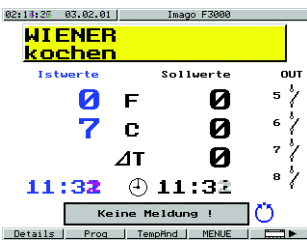
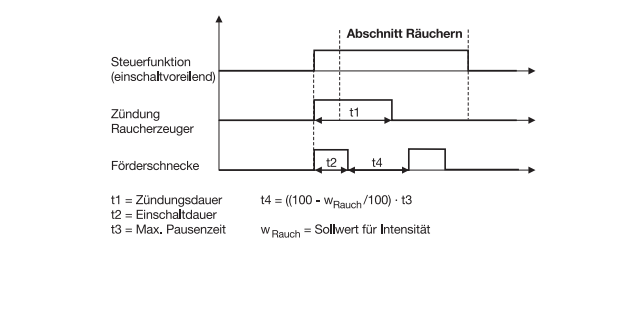

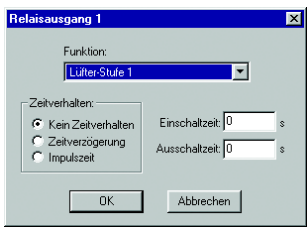
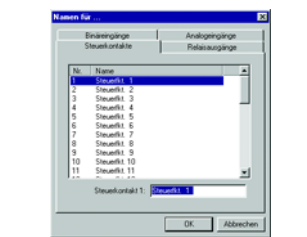
Extract from the parameter level

<p>Screen layout Three freely editable screens (for basic status, Automatic 1 and Automatic 2) are created in the setup program and then transferred to the instrument.</p>			
<p>Smoke generator The smoke generator is activated by an operating function. The smoke intensity can be altered while the profile program is running.</p>	 <p> $t1 = \text{Zündungsdauer}$ $t2 = \text{Einschaltdauer}$ $t3 = \text{Max. Pausenzeit}$ $t4 = ((100 - w_{\text{Rauch}}/100) \cdot t3)$ $w_{\text{Rauch}} = \text{Sollwert für Intensität}$ </p>		
<p>Function keys The instrument is supplied as standard with the function keys printed as shown on the right. Replaceable inserted strips can be used to provide other legends and functions.</p>		<p>Assignment of the relay outputs</p> <p>Each relay output can be assigned to an instrument function, a time event or an input/output switching action.</p>	
<p>Texts and names can be defined for: analog and logic inputs, operating contacts, relay outputs, process steps, programs, other languages.</p>		<p>Fan control</p> <p>The fan power stages can be switched on by various logic signals within the instrument, such as a limit comparator.</p>	

Electrical isolation

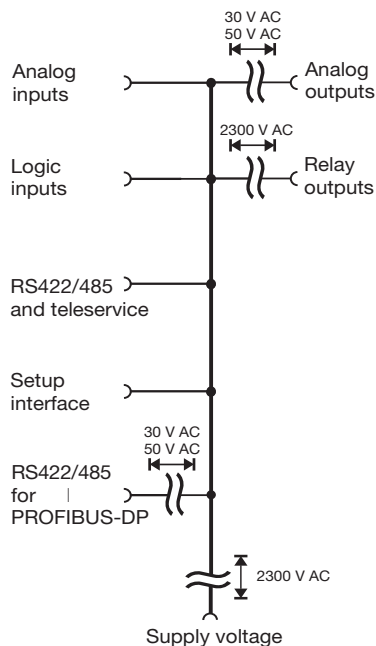

Technical data

Analog inputs (max. two I/O modules, each with 4 inputs)

Thermocouples	Range	Meas. accuracy	Ambient temperature error
Fe-Con L	-200 to + 900°C	≤0.4%	100 ppm/°C
Fe-Con J EN 60584	-200 to +1200°C	≤0.4%	100 ppm/°C
NiCr-Ni K EN 60584	-200 to +1372°C	≤0.4%	100 ppm/°C
Cold junction	internal Pt100		

Resistance thermometer	Connection type	Range	Meas. accuracy	Ambient temperature error
Pt100 EN 60751	3-wire	-200 to +850°C	≤0.1%	100 ppm/°C
Sensor lead resistance	max. 30Ω per conductor in 2-wire/3-wire circuit			
Measuring current	250μA			
Lead compensation	Not required for 3-wire circuit. For a 2-wire circuit, lead compensation can be provided in the software by a process value correction.			

Standard signals	Range	Meas. accuracy	Ambient temperature error
Voltage	0 – 1V, input resistance $R_E > 100k\Omega$ 0 – 10V, input resistance $R_E > 100k\Omega$	≤0.1% ≤0.1%	100 ppm/°C 100 ppm/°C
Current	0 – 20mA, voltage drop ≤ 1V 4 – 20mA, voltage drop ≤ 1V	≤0.1% ≤0.1%	100 ppm/°C 100 ppm/°C
Scaling	through software		

Measurement circuit monitoring ¹	Over/underrange	Probe/lead short-circuit ¹	Probe/lead break
Thermocouple	•	-	•
Resistance thermometer	•	•	•
Voltage 0 – 1V	•	-	-
0 – 10V	•	-	-
Current 0 – 20mA	•	-	-
4 – 20mA	•	•	•

• = recognized - = not recognized

1. In the event of an error, the outputs move to defined levels (configurable as: 0%, 100%, -100%).

Logic inputs (max. 2 I/O modules, each with 5 inputs, and max. 2 logic modules, each with 11 inputs)

Floating contacts	with common reference potential, configurable for PLC level through internal solder links
PLC level	low = 0 to 6V, high = 13 to 30V

Relay outputs (max. 3 relay modules, each with 10 outputs, and max. 2 logic modules, each with 5 outputs)

Relay (relay module)	2 changeover contacts, 8 make contacts
Relay (logic modules)	5 make contacts
- contact rating	3A at 250VAC, resistive load
- contact life	10 ⁶ operations at rated load between pole and make/break contact
- contact protection circuit	Varistor S14K300

Analog outputs (max. 1 I/O module with two outputs)

Voltage - output signals - load resistance	0 – 10V / 2 – 10V, can be changed over in software $R_{load} \geq 500 \Omega$
Current - outputs signals - load resistance	0 – 20mA / 4 – 20mA, can be changed over in software $R_{load} \leq 450 \Omega$

Controller

Number	four
Controller type	single-setpoint controller, double-setpoint controller, modulating controller, proportional controller, proportional controller with integrated actuator driver
Controller structures	P/PD/PI/PID/I
A/D converter	resolution better than 14 bit
D/A converter	13 bit
Sampling time	500ms
Sampling time for logic formulae, with read-in and output of the signals	100ms

Color display

Resolution	320 x 240 pixels
Size	5"
Number of colors	27 colors

Electrical data

Supply voltage (switchmode power supply)	110 – 240V AC -15/+10%, 48 – 63Hz 20 – 30V AC/DC, 48 – 63Hz
Power consumption	max. 44VA, p.f. ≤ 0.7
Data backup	EEPROM
Electrical connection	at rear by screw terminals, conductor cross-section up to 2.5mm ² and ferrules (length: 10mm)
Electrical safety	as per EN 61 010, Part 1 overvoltage category II, pollution degree 2
Electromagnetic compatibility - interference emission - interference immunity	to EN 61 326-1 Class B to industrial requirements

Housing

Housing type	plastic housing for panel mounting (indoor use) according to IEC 61554	
Dimensions in mm (for type ...)	700101/1, ...	700101/2, ...
Bezel	315 x 171 (portrait)	171 x 315 (landscape)
Mounting depth	103	103
Panel cut-out	138 ₀ ⁺¹ x 282 ₀ ^{+1.3}	282 ₀ ⁺¹ x 138 ₀ ^{+1.3}
Ambient/storage temperature range	0 to +50°C / -40 to +70°C	
Climatic conditions	rel. humidity not exceeding 95% annual mean, no condensation	
Site altitude	up to 2000 m above sea level	
Operating position	any	
Protection	to EN 60 529, front IP 67, rear IP 20	
Weight of minimal version (fully fitted)	approx. 1900 g (2300 g)	
Membrane keypad	Polyester membrane, protection: IP 67 resistant to normal cleaning agents and detergents	
Keys	Short-stroke keys with tactile feedback (click effect)	

Setup interface (electrically isolated)

Interface type	RS422/RS485
Protocol	always MODbus
Baud rate	9600 , 19200, 38400
Device address	1 – 255
Minimum response time	0 – 500ms

Universal interface**MODbus**

Interface type	RS422/RS485
Protocol	MODbus
Baud rate	9600 , 19200, 38400
Device address	1 – 255
Minimum response time	0 – 500ms

Approvals / approval marks

approval mark	Testing agency	Certificate/ Inspection number	Inspection basics	Valid for
c UL us	Underwriters Laboratories	20130925-E201387	UL 61010-1	all devices

bold print = factory setting

Connection diagram

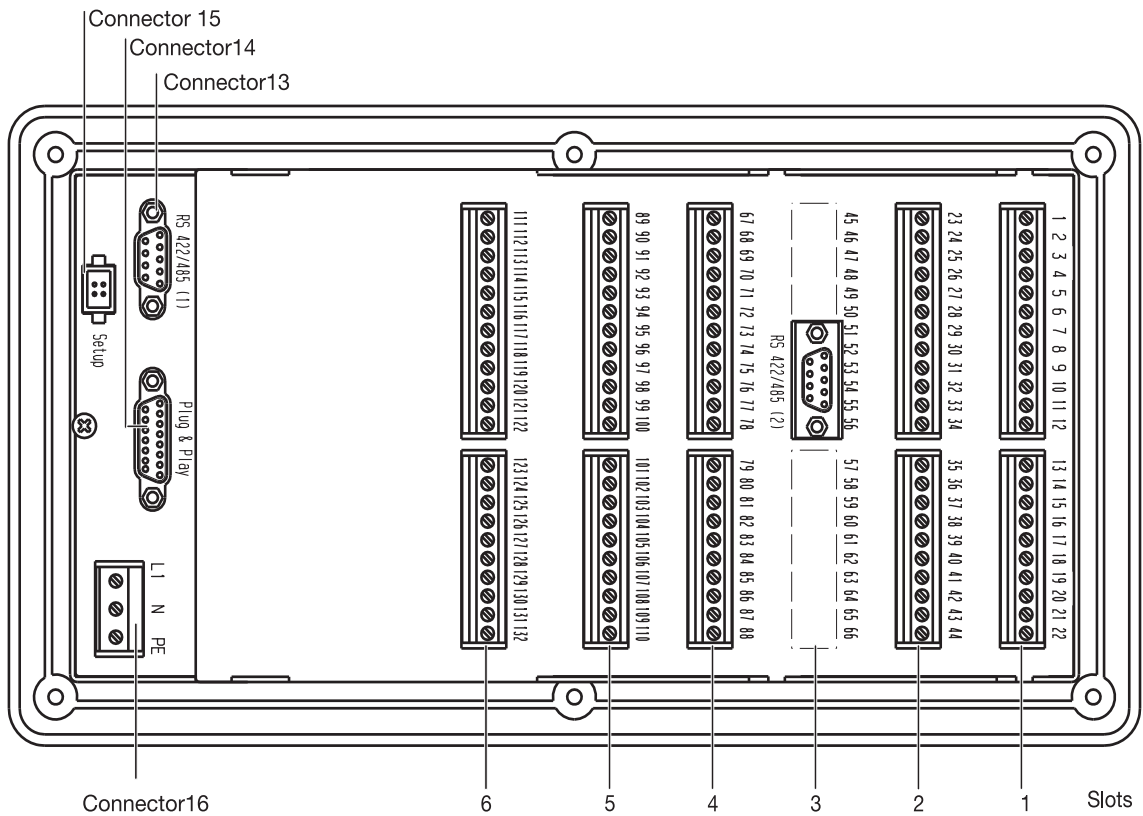

Note: the link positions must be altered for voltage or thermocouple inputs!

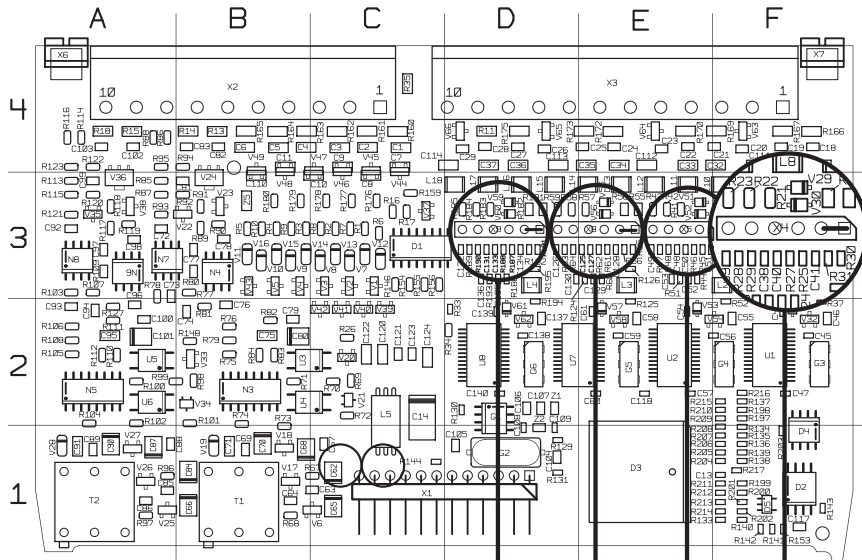

Analog input No.

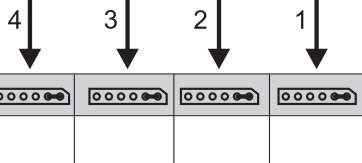

Pt100 (factory setting)

Your setting:











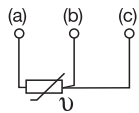

Setting options:

Only **one** link to be plugged in for each anaog input !



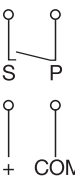

	Pt100
	0 — 10V
	0 — 1V and thermocouple

The current signal measurement does not depend on the position of the link !

I/O module (in slot 1)

	Analog input No.	1	2	3	4	Symbol	
	Thermocouple	1 + 3 -	4 + 6 -	7 + 9 -	10 + 12 -		
	Resistance thermometer	1 (a) 2 (b) 3 (c)	4 (a) 5 (b) 6 (c)	7 (a) 8 (b) 9 (c)	10(a) 11(b) 12(c)		
	Current input 0(4) – 20mA	2 + 3 -	5 + 6 -	8 + 9 -	11 + 12 -		
	Voltage 0(2) – 10V	1 + 3 -	4 + 6 -	7 + 9 -	10 + 12 -		
The analog inputs 1 and 2, 3 and 4, must be electrically isolated from one another!							
	Logic input No.	1	2	3	4	5	Symbol
	floating contact or PLC input: 24V DC LO level: 0 to 6V HI level: 13 to 30V	13 S (n.o. make) 18 P (common)	14 S 18 P	15 S 18 P	16 S 18 P	17 S 18 P	
		13 + 18 COM	14 + 18 COM	15 + 18 COM	16 + 18 COM	17 + 18 COM	
If PLC inputs are used, then the supply voltage for the logic inputs must be electrically isolated from the analog inputs!							
	Analog output No.	1	2	Symbol			
	0(4) – 20mA 0(2) – 10V configurable	19 + 20 -	21 + 22 -				

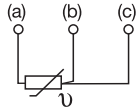

I/O module (in slot 2)

	Analog input No.	5	6	7	8	Symbol
	Thermocouple	23 + 25 -	26 + 28 -	29 + 31 -	32 + 34 -	
	Resistance thermometer	23(a) 24(b) 25(c)	26(a) 27(b) 28(c)	29(a) 30(b) 31(c)	32(a) 33(b) 34(c)	
	Current input 0(4) – 20mA	24 + 25-	27 + 28 -	30 + 31 -	33 + 34 -	
	Voltage 0(2) – 10V	23 + 25 -	26 + 28 -	29 + 31 -	32 + 34 -	

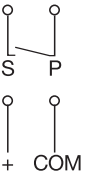
The analog inputs 5 and 6, 7 and 8, must be electrically isolated from one another!

	Logic input No.	6	7	8	9	10	Symbol
	floating contact or PLC input: 24V DC LO level: 0 to 6V HI level: 13 to 30V	35 S 40 P	36 S 40 P	37 S 40 P	38 S 40 P	39 S 40 P	
		35 + 40 COM	36 + 40 COM	37 + 40 COM	38 + 40 COM	39 + 40 COM	

If PLC inputs are used, then the supply voltage for the logic inputs must be electrically isolated from the analog inputs!

	Analog output No.	3	4	Symbol
	0(4) – 20mA 0(2) – 10V (configurable)	41 + 42 -	43 + 44 -	

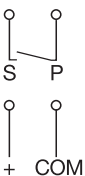

Logic module (in slot 3)

	Logic input No.	22	23	24	25	26	27	28	29	30	31	32	Symbol
	floating contact or PLC input: 24V DC LO level: 0 to 6V HI level: 13 to 30V	45 S 56 P	46 S 56 P	47 S 56 P	48 S 56 P	49 S 56 P	50 S 56 P	51 S 56 P	52 S 56 P	53 S 56 P	54 S 56 P	55 S 56 P	
		45 + 56 COM	46 + 56 COM	47 + 56 COM	48 + 56 COM	49 + 56 COM	50 + 56 COM	51 + 56 COM	52 + 56 COM	53 + 56 COM	54 + 56 COM	55 + 56 COM	

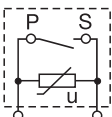
If PLC inputs are used, then the supply voltage for the logic inputs must be electrically isolated from the analog inputs!

	Relay output No.	31	32	33	34	35	Symbol
	3A 230V	57 P 58 S	59 P 60 S	61 P 62 S	63 P 64 S	65 P 66 S	

Universal interface (in slot 3)

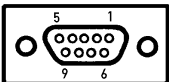
	Connection for	Assignment	PROFIBUS-DP	Symbol
 	RS422 interface, electrically isolated	4 RxD (+) 9 RxD (-) 3 TxD (+) 8 TxD (-) 5 GND	8 A(+) 3 B(-) 6 VCC 5 GND 9 GND	
	RS485 interface, electrically isolated	3 RxD/TxD A(+) 8 RxD/TxD B(-) 5 GND		

Relay module (in slot 4)

	Relay output No.	1	2	3	4	5	Symbol
		3A 230V	67 P 68 O 69 S	70 P 71 O 72 S	73 P 74 S	75 P 76 S	77 P 78 S
Relay output No.		6	7	8	9	10	Symbol
	3A 230V	79 P 80 S	81 P 82 S	83 P 84 S	85 P 86 S	87 P 88 S	

Relay module (in slot 5)

	Relay output No.	11	12	13	14	15	Symbol
		3A 230VA	89 P 90 O 91 S	92 P 93 O 94 S	95 P 96 S	97 P 98 S	99 P 100 S
Relay output No.		16	17	18	19	20	Symbol
	3A 230V	101 P 102 S	103 P 104 S	105 P 106 S	107 P 108 S	109 P 110 S	

Logic module (in slot 6)

	Logic input No.	11	12	13	14	15	16	17	18	19	20	21	Symbol
		floating contact or PLC input: 24V DC LO level: 0 to 6V HI level: 13 to 30V	111 S 122 P	112 S 122 P	113 S 122 P	114 S 122 P	115 S 122 P	116 S 122 P	117 S 122 P	118 S 122 P	119 S 122 P	120 S 122 P	121 S 122 P
		111+ 122 COM	112+ 122 COM	113+ 122 COM	114+ 122 COM	115+ 122 COM	116+ 122 COM	117+ 122 COM	118+ 122 COM	119+ 122 COM	120+ 122 COM	121+ 122 COM	

If PLC inputs are used, then the supply voltage for the logic inputs must be electrically isolated from the analog inputs!

	Relay output No.	26	27	28	29	30	Symbol
		3A 230V	123 P 124 S	125 P 126 S	127 P 128 S	129 P 130 S	131 P 132 S

Relay module (in slot 6)

Relay output No.	21	22	23	24	25	Symbol
3A 230VA	111 P 112 O 113 S	114 P 115 O 116 S	117 P 118 S	119 P 120 S	121 P 122 S	
Relay output No.	26	27	28	29	30	Symbol
3A 230V	123 P 124 S	125 P 126 S	127 P 128 S	129 P 130 S	131 P 132 S	

Connector 13

Teleservice, visualization	RS422	RS485	Symbol
RS422/485 interface	4 RxD (+) 9 RxD (-) 3 TxD (+) 8 TxD (-) 5 GND	8 RxD/TxD B(-) 3 RxD/TxD A(+) 5 GND	

Connector 14

Connection for	Assignment	Symbol
Plug & Play interface		

Connector 15

Connection for	Assignment	Symbol
Setup connector	PC interface with TTL/RS232 converter (This is not electrically isolated from the analog inputs, logic inputs, and the teleservice interface.)	

Connector 16

Connection for	Assignment	Symbol
Supply voltage, as per nameplate	L1 phase/line N neutral PE protective earth	

Dimensions

Type 700101/1, ... portrait format

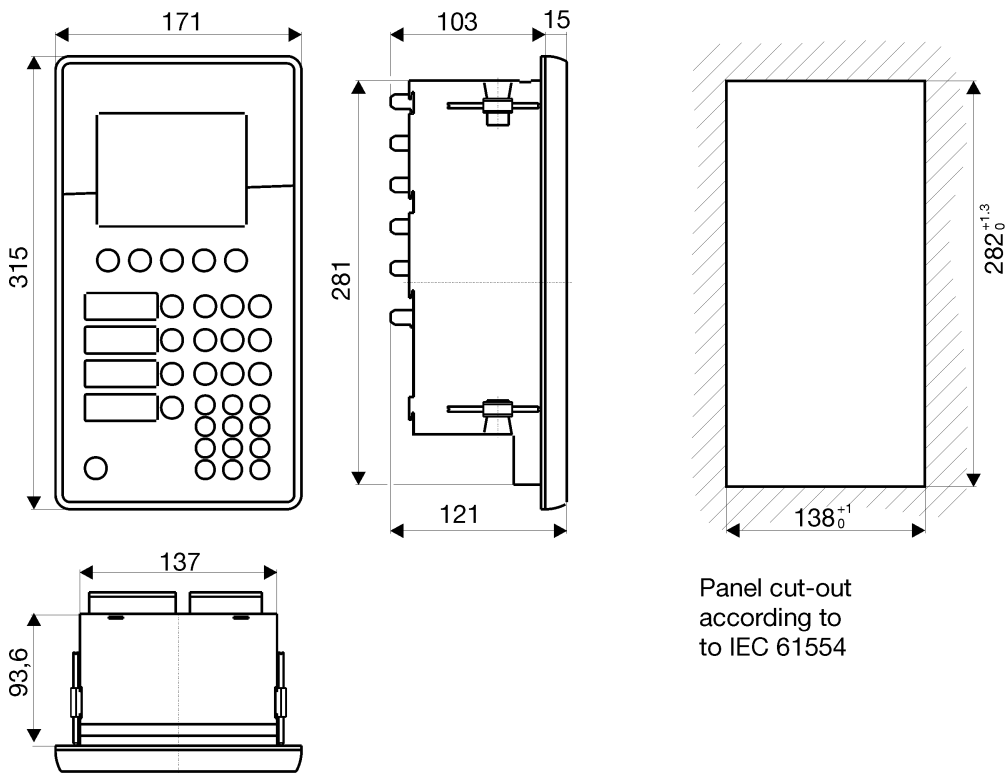

Type 700101/2, ... landscape format

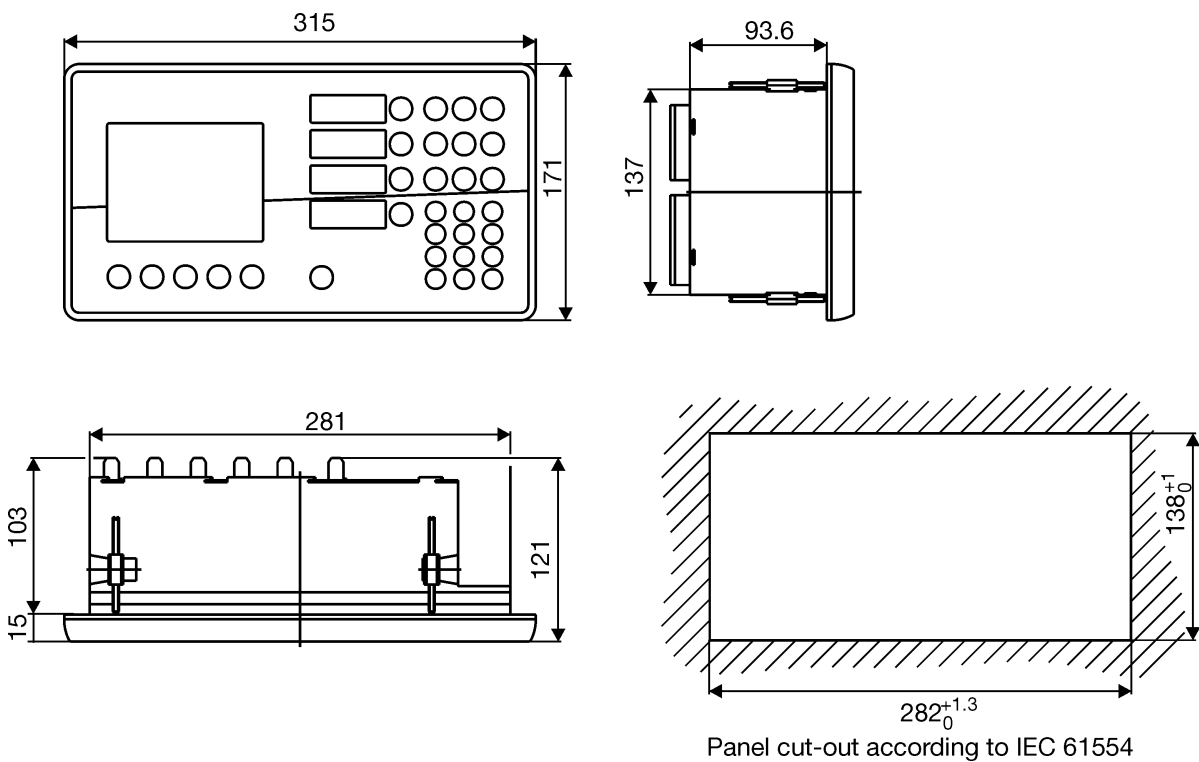

Order details: JUMO IMAGO F3000 process controlles for the meat processing industry

(1) Basic type

700101 JUMO IMAGO F3000

(2) Basic type extensions

Format

- x 1 315 mm x 171 mm, portrait format
- x 2 171 mm x 315mm, landscape format

Version

- x 8 standard, with factory settings
- x 9 customized programming according to specification

Language for the configuration level

- x 1 German
- x 2 English
- x 3 French
- x 5 Russian

(3) Slot assignments

Code Plug-in cards for inputs, outputs and interfaces

Code	Plug-in cards for inputs, outputs and interfaces	Slot Number					
		1	2	3	4	5	6
	minimum assignment	2	0	0	1	0	0
1	relay module: 10 relay outputs (8 make, 2 changeover)	-	-	-	X	X	X
2	input module: 4 analog inputs, 5 logic inputs for floating contacts	X	X	-	-	-	-
3	I/O module: 4 analog inputs, 5 logic inputs for floating contacts, 2 analog outputs	X	X	-	-	-	-
4	logic module: 11 logic inputs for floating contacts, 5 relay outputs (make)	-	-	X	-	-	X
5	universal interface MODbus (electrically isolated)	-	-	X	-	-	-
6	universal interface PROFIBUS-DP (electrically isolated)	-	-	X	-	-	-
7	I/O module: 4 analog inputs, 5 logic inputs for PLC level	X	X	-	-	-	-
8	I/O module: 4 analog inputs, 5 logic inputs for PLC level, 2 analog outputs	X	X	-	-	-	-
9	Logic module: 11 logic inputs for PLC level, 5 relay outputs (make)	-	-	X	-	-	X

- assignment not possible
 X assignment possible
 0 free
 ■ factory-set

(4) Supply voltage

- x 2 3 110 – 240V AC, -15/+10%, 48 – 63Hz
- x 2 5 20 – 30V AC/DC, 48 – 63Hz

(5) Interface for teleservice and visualization

- x 0 0 no interface
- x 5 4 RS422/485 interface (MODbus slave, connector 13)

(6) Extra code

- x 0 0 0 no extra code
- x 2 1 1 Plug & Play memory
- x 2 1 3 recording function

(1) (2) (3) (4) (5) (6)

Order code

/ - - - /

Order example

700101 / 181 - 200100 - 23 - 00 / 000

Plug-in cards for retrofitting/converting

Available from stock:

- Relay module: 10 relay outputs (8 make, 2 changeover)
- Input module: 4 analog inputs, 5 logic inputs
- I/O module: 4 analog inputs, 5 logic inputs, 2 analog outputs
- Logic module: 11 logic inputs, 5 relay outputs (make)
- Interface for teleservice and visualization, RS422/485 (connector 13, MODbus slave, Code 54)

Delivery time approx. 2 weeks:

- Universal interface MODbus (slot 3) 70/00411250
- Universal interface for PROFIBUS-DP (slot 3) 70/00411248
- Input module for PLC level 70/00433065
- Logic module for PLC level 70/00433064

Sales No.

Accessories - Price Sheet 70.9770

- Program editor, multilingual
- Setup program and program editor, multilingual
- Setup program, program editor and teleservice, multilingual
- PC interface with TTL / RS232 converter (socket)
- Interface converter RS232 to RS422
- Plug-in power supply for interface converter

Sales No.

- 70/00398294
- 70/00398296
- 70/00398297
- 70/00301315
- 70/00376969
- 70/00365933

Accessories

- Plug & Play memory
- Enable recording function
- Mounting brackets for installation in LPF-200 / MPF-88 front panel cut-out

Sales No.

- 70/00398298
- 70/00433789
- 70/00413524