

# FK 1100 DIAPHRAGM LIQUID PUMP



FK 1100 KPDCB-4



FK 1100 KP .51 DCB-4



FK 1100 KP AC

## ADVANTAGES

- Low pulsation
- Excellent linearity
- High chemical resistance
- Self-priming
- Dry-run proof

## POSSIBLE AREAS OF USE

- Inkjet printing
- Food & beverage industry
- Cleaning and disinfection
- Pharmaceutical processes
- Chemical industry
- Agriculture

Please visit our website  
[www.knf.com](http://www.knf.com)  
to get more information.

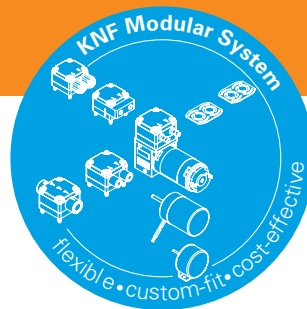

PERFORMANCE DATA			
Series model	FK 1100 DCB-4*	FK 1100 AC 50 Hz	FK 1100 AC 60 Hz
Material options	KP/KP .51**	KT	
Pump head: Connection plate	PP		
Pump head: Intermediate plate	PPS		
Diaphragm	PTFE		
Valves	EPDM	FFKM	
Resonating diaphragm	EPDM	FKM	
Flow rate at atm. pressure (l/min)	12.4		11.5
Suction height (mH <sub>2</sub> O/inHg)	4.5/13		4/11.6
Pressure head (mH <sub>2</sub> O/psig)	10/14.2		
Permissible ambient temp. (°C/°F)	+5 ... +60/+41 ... +140		
Permissible liquid temperature (°C/°F)	+5 ... +80/+41 ... +176		
Weight (kg/lbs)	7.7/17	11/24.3	11/24.3
IP protection factor pump	50	54	54
ELECTRICAL DATA			
Operating voltage (V)	24	200-240	100-120
Power consumption (W)	130	165-235	170-220
I max. Start @ 25 °C (A)	4.2	1.1-1.5	1.9-2.1
IP protection factor motor	50	54	54

\* DCB = Stands for brushless DC motor  
\*\* food grade conformity according to the standard NSF/ANSI 169

# FK 1100 DCB-4

## PERFORMANCE DATA

Series model	Flow rate at atm. pressure (l/min)	suction height (mH <sub>2</sub> O/inHg)	Max. pressure head (mH <sub>2</sub> O/psig)
FK 1100 DCB-4	12.4	4.5/13	10/14.2

## FK 1100 DCB-4

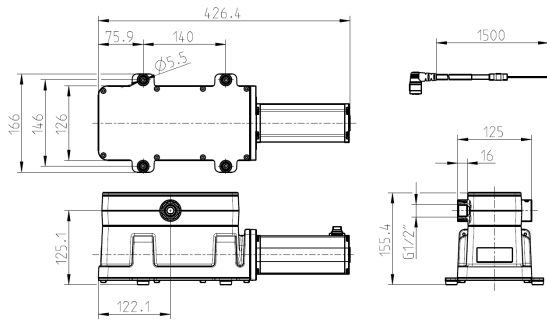

Dimensions in mm

## FK 1100 FLOW CURVE

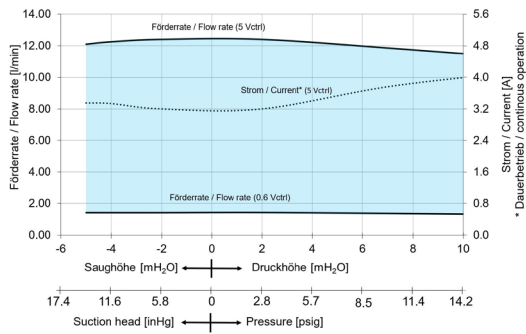

## FK 1100 CONTROL CURVE

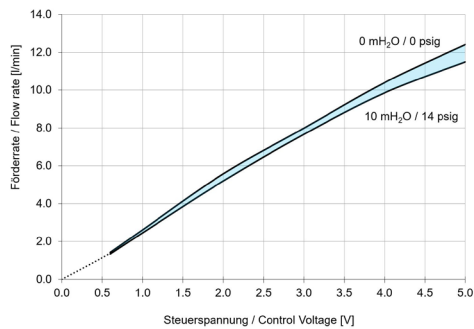

## ELECTRIC SPECIFICATIONS

Connection type	Plug, cable included
Wires	0.22/1.0 mm <sup>2</sup>
Wires assignment	red / blue = +VS black / violet = - VS/GND pink = Vctrl-input orange = FG-output
Input signal	Vctrl/PWM
Supply voltage (VS)	24 VDC
Input signal range Vctrl	0 - 5V
Input signal range PWM	0 - 100%

# FK 1100 AC 50 Hz

## PERFORMANCE DATA

Series model	Flow rate at atm. pressure (l/min)	suction height (mH <sub>2</sub> O/inHg)	Max. pressure head (mH <sub>2</sub> O/psig)
FK 1100 AC	12.4	4.5/13	10/14.2

# FK 1100 AC 60 Hz

## PERFORMANCE DATA

Series model	Flow rate at atm. pressure (l/min)	suction height (mH <sub>2</sub> O/inHg)	Max. pressure head (mH <sub>2</sub> O/psig)
FK 1100 AC	11.5	4/11.6	10/14.2

## FK 1100 AC 50 HZ

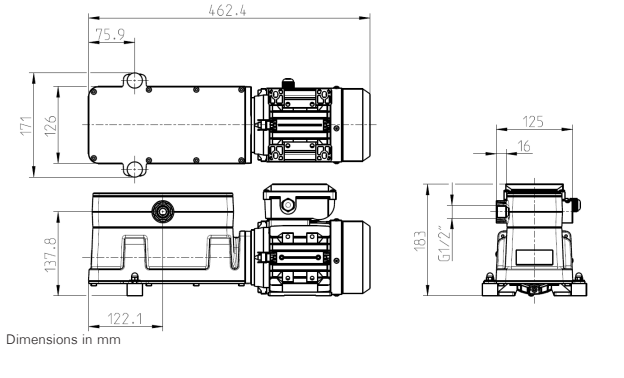

## FK 1100 AC 60 HZ

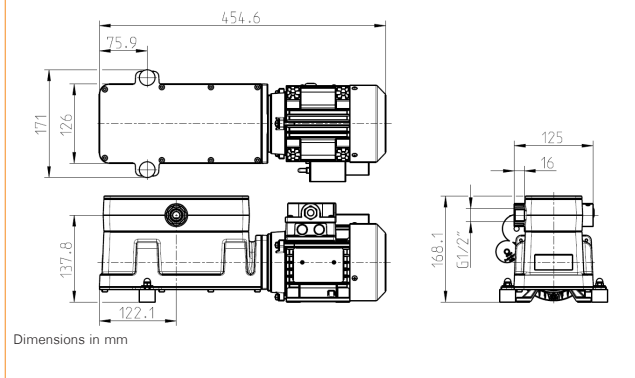

## FK 1100 AC 50 HZ FLOW CURVE @ 230V

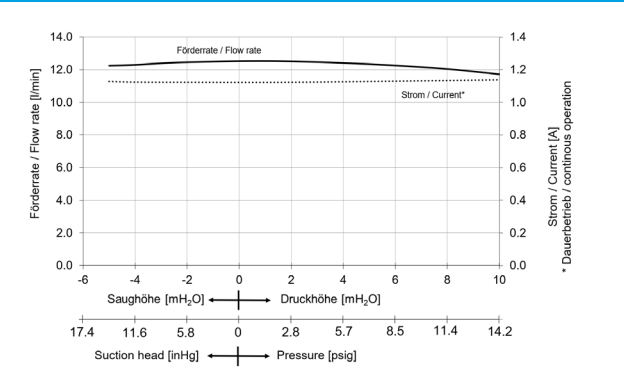

## FK 1100 AC 60 HZ FLOW CURVE @ 115V

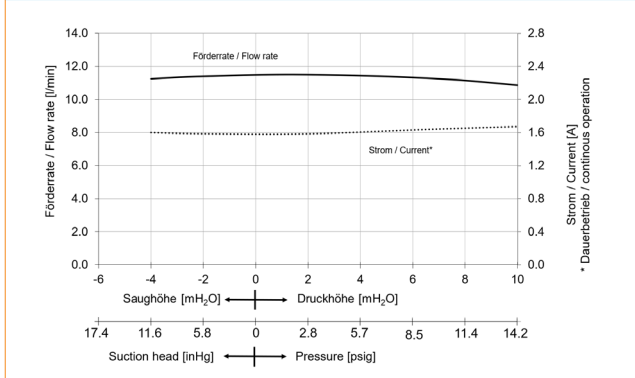

## ELECTRIC SPECIFICATIONS

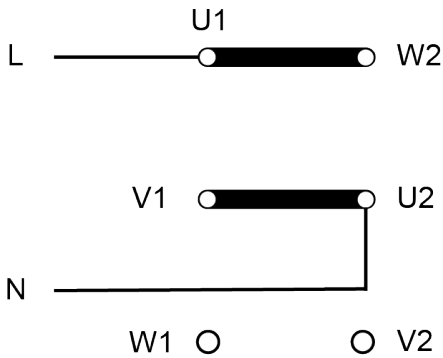

Connection type	Connection box
-----------------	----------------

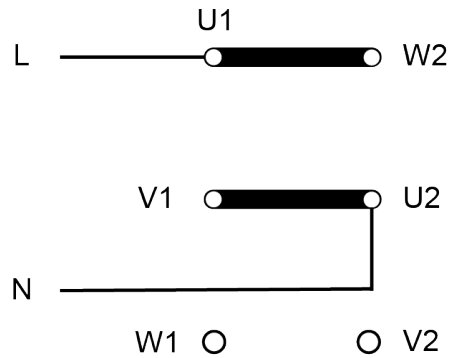

## ELECTRIC SPECIFICATIONS

Connection type	Connection box
-----------------	----------------





OPTIONS		
Description	Illustration	Details
Brushed DC motor		Cost-effective drive with reduced lifetime expectation. Supply voltage: 24 VDC
Three-phase AC motor		Best for controlled operation with a frequency converter. Supply voltage: 230/400 VAC
Pressure relief valve		Passive diaphragm valve to protect the pump from pressure peaks on the outlet. The required pressure can be set by a spindle/spring combination.
Other diaphragm materials		Following additional material is available:  EPDM



### NSF National Sanitary Foundation

This certification will confirm that all of the pumps with the code .51 are certified for the use with foods/consumables.

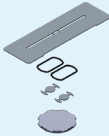
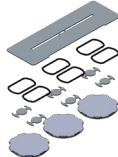
ACCESSORIES			
Description	Illustration	Part No.	Details
Compression fitting		176189	Connection for flexible tubes suitable for higher pressures. Connection: DN16/22 Material: PP O-Ring: FKM
Hose connector		178172	Straight hose barb suitable for lower pressures. Connection: DN16 Material: PP O-Ring: FKM
Spare Parts Set "small"		KP:177998 KT: 177999	Contains following elastomer parts: 1 pc. Diaphragm 2 pcs. Anchor valves 2 pcs. O-rings 1 pc. Resonating diaphragm
Spare Parts Set "large"		KP:178000 KT: 178001	Contains following elastomer parts: 3 pcs. Diaphragms 6 pcs. Anchor valves 6 pcs. O-rings 1 pc. Resonating diaphragm

The performance values for the series models shown on this data sheet were determined under test conditions. The actual performance values may differ and depend in particular on the usage conditions and therefore on the specific application, on the parameters of the components involved in the user's system and on any technical modifications carried out which deviate from the standard configuration or the as delivered condition.

If individual designs have been created for specific customers on the basis of series models, other technical performance data may apply. Before operation begins, the relevant operating instructions and/or assembly or installation instructions should be read and the safety information contained in these instructions should be noted. KNF reserves the right to make changes to the product and the associated documentation without prior notice to the customer.



[www.knf.com](http://www.knf.com)