

Flow Monitor

RVM/U-2



OVERVIEW

Operation

- Float measuring principle

Application

- Cooling systems and cooling circuits
- Mechanical engineering
- Medical engineering
- Pharmaceutical industry
- Chemical industry
- Research & Development

Features

- Universal orientation
- High reliability
- High switch accuracy
- Infinitely variable switch point adjustment by operator
- EX-version according to ATEX directive available
- High pressure resistance
- Threaded connection, special thread on request

Installation information

- The operating instructions for RVM/U-2 Module BASICS / ...ATEX must be observed!
- **Download: www.meister-flow.com**

OPERATING DATA

Operating pressure, max.	300 bar (Brass version)
	350 bar (Stainless steel version)
Pressure drop	0,02 – 0,3 bar
Temperature, max.	100 °C (optional 160 °C)
Measuring accuracy	±10 % of full scale

Changed operating data apply to the device in explosion-proof design according to ATEX directive. Refer to the Operating Instructions for RVM/U-2 Module ATEX.

Download: www.meister-flow.com

MEASURING RANGES

Type	Switch range for H ₂ O at 20 °C ⁽¹⁾		
	l/min	gph	gpm
RVM/U-2/02	0,02 – 0,2	0,3 – 3,35	
RVM/U-2/06	0,2 – 0,6	3,2 – 9,5	
RVM/U-2/1	0,4 – 1,8	6,5 – 28,5	
RVM/U-2/3	0,8 – 3,2	13 – 51	
RVM/U-2/7	2 – 7	32 – 111	
RVM/U-2/13	3 – 13	48 – 205	
RVM/U-2/20	4 – 20	65 – 315	
RVM/U-2/30	8 – 30	130 – 480	

⁽¹⁾ The specified measuring- / switch ranges are valid for water having a density of 1.00 kg/dm³, vertical installation of the device and flow direction from bottom to top.

Other installation positions or deviation from the operating densities will increase the measurement error specified in the data sheet.

Operating density for water at 20 °C and 1.013 bar (absolute value): 1.00 kg/dm³.

Upon request, special scales for deviating media, different operating conditions and installation positions (only for devices which can be installed in any position) are available.

The specified switch values are switch-off points, i.e. switch values by decreasing flow.

Other measuring- /switch ranges are available upon request.

MATERIALS

Brass version, wetted parts	
Spring:	1.4571
Gaskets:	NBR (optional FKM, EPDM) ⁽²⁾
Magnets:	Hard ferrite
Device body:	Brass, nickel-plated
all other wetted parts:	Brass

Stainless steel version, wetted parts	
Spring:	1.4571
Gaskets:	FKM (optional NBR, EPDM) ⁽²⁾
Magnets:	Hard ferrite
Device body:	1.4571
all other wetted parts:	1.4571

⁽²⁾ Other gasket materials on request

TECHNICAL DRAWING

For devices with switch contact 15x50

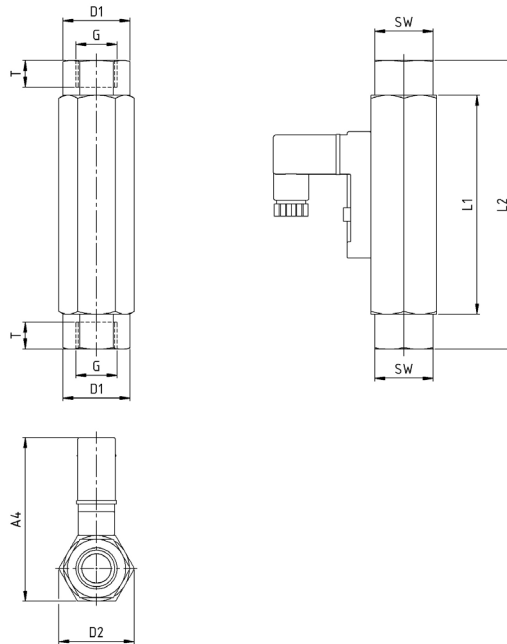

SUMMARY OF TYPES

For devices with switch contact 15x50

Type	Overall dimensions [mm]												Weight approx. [g] ⁽⁴⁾
	G ⁽³⁾	DN	SW	L1	L2	T	D1	D2	A1	A2	A3	A4	
RVM/U-2/02 RVM/U-2/06	1/4"	8	24	90	98,0	10	27,7	31,2	-	-	-	≈67	350
	3/8"	10	24	90	118,6	11	27,7	31,2	-	-	-	≈67	350
	1/2"	15	27	90	-	14	-	31,2	-	-	-	≈67	350
RVM/U-2/1 RVM/U-2/3	1/4"	8	24	90	98,0	10	27,7	31,2	-	-	-	≈67	350
	3/8"	10	24	90	118,6	11	27,7	31,2	-	-	-	≈67	350
	1/2"	15	27	90	-	14	-	31,2	-	-	-	≈67	350
RVM/U-2/7 RVM/U-2/13	1/4"	8	24	90	98,0	10	27,7	31,2	-	-	-	≈67	350
	3/8"	10	24	90	118,6	11	27,7	31,2	-	-	-	≈67	350
	1/2"	15	27	90	-	14	-	31,2	-	-	-	≈67	350
RVM/U-2/20 RVM/U-2/30	1/2"	15	27	90	-	14	-	31,2	-	-	-	≈67	350

⁽³⁾ NPT thread on request

⁽⁴⁾ Connection cable weight, 2 m approx. 80 g

TECHNICAL DRAWING

For devices with switch contact 30x70

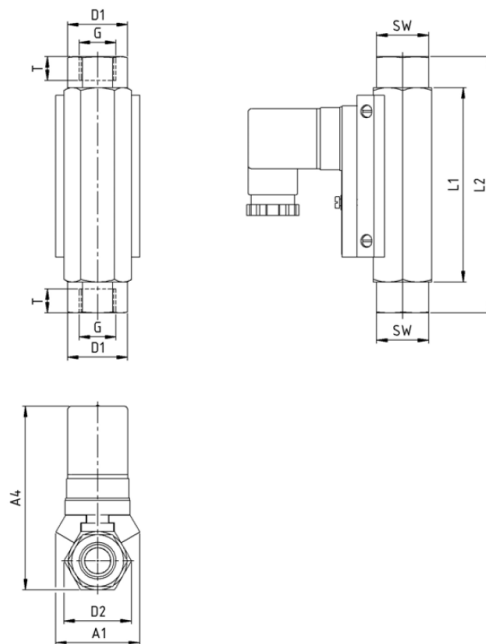

SUMMARY OF TYPES

For devices with switch contact 30x70

Type	Overall dimensions [mm]											Weight approx. [g] ⁽⁶⁾	
	G ⁽⁵⁾	DN	SW	L1	L2	T	D1	D2	A1	A2	A3		A4
RVM/U-2/02 RVM/U-2/06	1/4"	8	24	90	98,0	10	27,7	31,2	38,9	-	-	≈85	350
	3/8"	10	24	90	118,6	11	27,7	31,2	38,9	-	-	≈85	350
	1/2"	15	27	90	-	14	-	31,2	38,9	-	-	≈85	350
RVM/U-2/1 RVM/U-2/3	1/4"	8	24	90	98,0	10	27,7	31,2	38,9	-	-	≈85	350
	3/8"	10	24	90	118,6	11	27,7	31,2	38,9	-	-	≈85	350
	1/2"	15	27	90	-	14	-	31,2	38,9	-	-	≈85	350
RVM/U-2/7 RVM/U-2/13	1/4"	8	24	90	98,0	10	27,7	31,2	38,9	-	-	≈85	350
	3/8"	10	24	90	118,6	11	27,7	31,2	38,9	-	-	≈85	350
	1/2"	15	27	90	-	14	-	31,2	38,9	-	-	≈85	350
RVM/U-2/20 RVM/U-2/30	1/2"	15	27	90	-	14	-	31,2	38,9	-	-	≈85	350

⁽⁵⁾ NPT thread on request

⁽⁶⁾ Connection cable weight, 2 m approx. 80 g

ELECTRICAL DATA

For devices with switch contact 15x50

Change over (COC) ⁽⁷⁾	250V · 1,5A · 50VA ⁽⁸⁾
Normally open (NOC)	230V · 3A · 60VA
Change over M12x1 (-20 °C – 85 °C)	125V · 1,5A · 50VA ⁽⁸⁾
Normally open M12x1 (-20 °C – 85 °C)	125V · 3A · 60VA
Change over PLC ⁽⁷⁾	250V · 1A · 60VA

EX-version in compliance with ATEX directive

EC-Type examination

EPS 13 ATEX 1 596 U

Connection to certified intrinsically safe circuits

Li = 0

Ci = 0

Gas			Dust		
Ui	Ii	Pi	Ui	Ii	Pi
< 12,1 V	1,0 A	3,0 W	< 12,1 V	0,25 A	0,75 W
< 20 V	0,309 A	1,55 W	< 20 V	0,25 A	0,75 W
< 25 V	0,158 A	0,99 W	< 25 V	0,25 A	0,75 W
< 30 V	0,101 A	0,76 W	< 30 V	0,25 A	0,75 W

Operating temperature

-5 °C < T_{Service} < 45 °C

⁽⁷⁾ Available with connector only

⁽⁸⁾ Minimum load 3VA

Marking

⊕ II 2G Ex ib IIC
⊕ II 2D Ex ib IIIC

ELECTRICAL CONNECTION

For devices with switch contact 15x50

- Connector in compliance with EN 175301-803, Form C (DIN 43650, Form C)
- Connector M12x1
- Cable (1 m) ⁽⁹⁾

EX-version in compliance with ATEX directive

- Connector in compliance with EN 175301-803, Form C (DIN 43650, Form C)
- Connector M12x1
- Cable (1 m) ⁽⁹⁾

Ingress Protection

IP65: Connector in compliance with EN 175301-803, Form C or Connector M12x1

IP67: Cable

Output signal

The contact opens / changes when the flow decreases below the set point.

Power supply

Not required (potential-free reed contacts)

Connector types

Other connector types or cable lengths on request

⁽⁹⁾ Available as Normally Open Contact (NOC) only

CONNECTION DIAGRAM

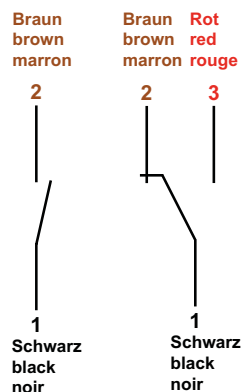

ELECTRICAL DATA

For devices with switch contact 30x70

Change over (COC)	250V · 1,5A · 50VA ⁽¹⁰⁾
Normally open (NOC)	250V · 3A · 100VA
Change over M12x1 (-20 °C – 85 °C)	250V · 1,5A · 50VA ⁽¹⁰⁾
Normally open M12x1 (-20 °C – 85 °C)	250V · 3A · 100VA
Change over PLC	250V · 1A · 60VA

EX-version in compliance with ATEX directive

ATEX II 2 G Ex mb IIC T6 Gb & ATEX II 2 D Ex tb IIIC T80 °C Db

ATEX II 2 G Ex mb IIC T5 Gb & ATEX II 2 D Ex tb IIIC T100 °C Db

Change over	250V · 1A · 30VA ⁽¹⁰⁾
Normally open	250V · 2A · 60VA

⁽¹⁰⁾ Minimum load 3VA

ELECTRICAL CONNECTION

For devices with switch contact 30x70

- Connector in compliance with EN 175301-803, Form A (DIN 43650, Form A)
- Connector M12x1
- Cable (1 m)

EX-version in compliance with ATEX directive

- Cable (2 m)

Ingress Protection

IP65: Connector in compliance with EN 175301-803, Form A
IP67: Cable or connector M12x1

Output signal

The contact opens / changes when the flow decreases below the set point.

Power supply

Not required (potential-free reed contacts)

Connector types

Other connector types or cable lengths on request

CONNECTION DIAGRAM

