

# MACP200 series

AIR UNIT (F.R.L.UNIT)

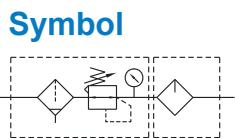

## Specification

Model	MACP200	
Components	MAFR200, MAL200	
Bore No.	6A	8A
Port size	1/8	1/4
Medium	Air	
Operating perssure range (*)	0.05~1 MPa	
Proof pressure	1.5 MPa	
Regulated pressure range	0.05~0.85 MPa	
Ambient temperature	- 5~+60°C (No freezing)	
Filter element	Standard: 40μm, Option: 5μm	
Lubricating oil capacity	20c.c, 35c.c (MACP200L)	
Min. flow for oil drip	35 ℓ/min	50 ℓ/min
Recommended lubricating oil	Turbine oil ISO-VG32	
Attachment	Pressure gauge (PG-40), L-type bracket	
Weight	432 g, 380 g (MACP200L)	

\* Standard unit contains semi-auto-drain function when operating pressure below 0.05 MPa.

## Order example

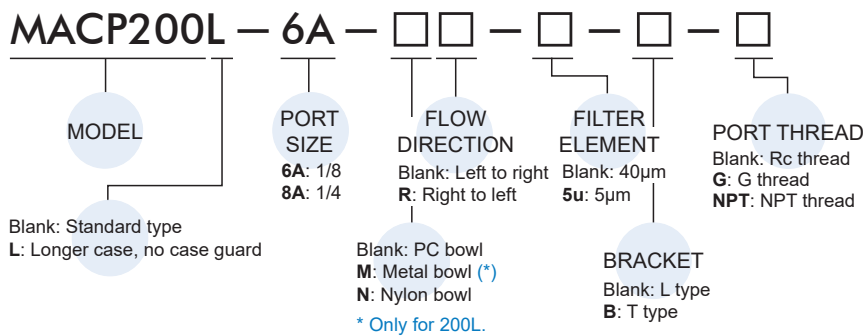

## Flow feature

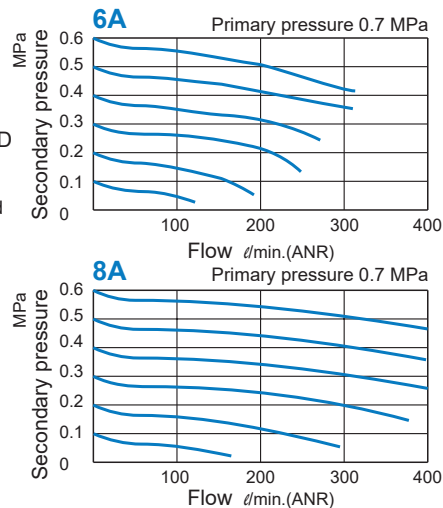

# MACP200 Dimensions

AIR UNIT (F.R.L.UNIT)



## MACP200-B

T type bracket

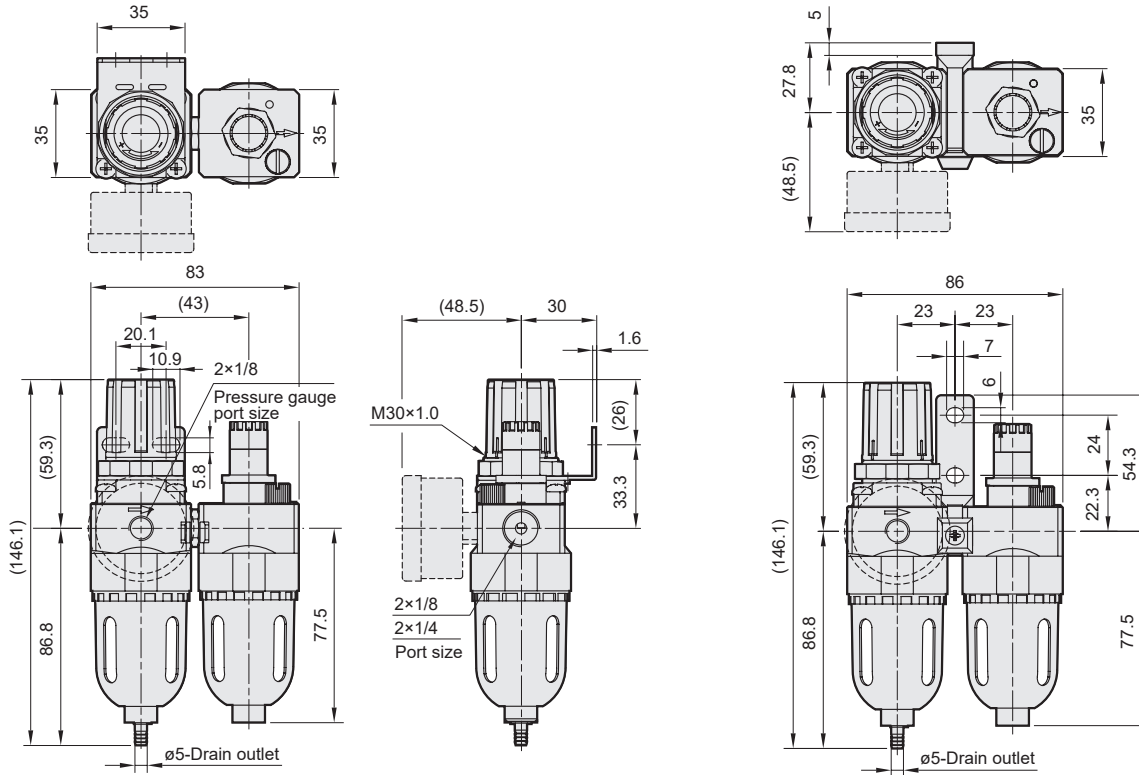

## MACP200L-M-B

Metal bowl + T type bracket

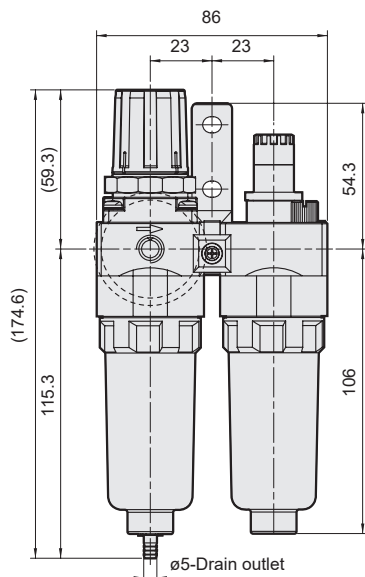

## MACP200L-B

T type bracket

